

K – 1<sup>st</sup> grade • English Level 2

# Learning Packet #5

Theme: Hygiene



# International Consortium for Multilingual Excellence in Education



August 15<sup>th</sup>, 2020

Dear District/School Personnel:

We are a consortium of researchers, teacher educators, and teachers who believe in and strive to foster multilingual excellence. Therefore, during this time of crisis and difficulty, we are eager to put our expertise and passions to use to try to be of assistance. We initially designed 21 immediate-response packets for K-5, as soon as the pandemic forced schools to shut down. We then applied for and received a grant that has allowed us to create more than 100 full activity packets, ranging from Levels 1-3 of English proficiency, and grades K-12.

**The breakdown of packets is as follows:**

## **Level 1 – Entry into English**

Emphasis on developmentally appropriate interesting/challenging tasks

- K-2
- 3-5
- 6-8 with a literacy background
- 9-12 with a literacy background
- 6-8 without literacy background
- 9-12 without literacy background

## **Level 2 – Building Background**

- K-1
- 2-3
- 4-5
- 6-8
- 9-10
- 11-12

## **Level 3 – Interdisciplinary Inquiry**

- K-1
- 2-3
- 4-5
- 6
- 7-8
- 9-10
- 11-12

With this letter, is an “Activity Packet” that can be used freely with any group of students or families as you see fit. Each packet includes interdisciplinary activities designed to be completed within a week. Teachers from around the country have designed, developed, and created these packets, each focusing on the topics of their choice. Because learning academic content can happen within any thematic context, these packets are designed to be diverse, dynamic, and engaging for students of all backgrounds. The topics covered in these units range from cultures, animals, natural disasters, inventions, and much more. You will see each teacher’s personality reflected strongly in these packets, and our hope is that this will capture students in a way similar to that of a rich and immersive classroom environment.

# International Consortium for Multilingual Excellence in Education



Our hope is that these materials can provide some meaningful learning supports to students and families who may not have access to online learning opportunities. However, we can also imagine a variety of ways that these packets can provide learning opportunities outside of our original intent and purpose. Please use these activity packets in any way you see fit for your students and families. We will be so pleased to learn of how they might be useful, particularly for your multilingual students and their families. We think it might be particularly helpful for you to print packets and mail them to families, but we also see opportunities to work with local agencies, leave printed-out packets for pick-ups at schools, etc.

We designed these activities based around several big ideas:

- Productive play and inquiry
- Grade level and English Language Development standards/curriculum
- Fostering multilingual language development
- Providing opportunity for all four language domains (reading, writing, speaking and listening)

These packets are self-contained. Everything a child will need to be successful with the activities is provided in the packet. Students will only need a writing utensil. Additional tools like crayons or scissors are optional.

We have also included a letter to parents. We hope this will help parents understand what students will be doing with the packet and that we encourage the use of all language resources available to the student. The packets are in English for the students, but the students can write, talk and engage with family members regarding the packet activities in any language they would like. We have translated the parent letter into Spanish, and we encourage districts to translate the letter into any other language that would be helpful for your local families.

Designing Activity Packets is a new initiative for us, though we have been designing professional learning opportunities (eWorkshops) for teachers of multilingual learners since 2011. Like our Activity Packets, those learning opportunities for teachers are free. To learn more about them and us, please visit our website at: <https://cehs.unl.edu/icmee/>

We are eager to be a helpful, collaborative partner in all learning needs related to multilingual students and their teachers, so please, do not hesitate to reach out to us with questions, ideas, concerns, feedback, etc. We are available at [icmee@unl.edu](mailto:icmee@unl.edu).

Sincerely,

Kara Mitchell Viesca, PhD

Associate Professor of Language Education

University of Nebraska Lincoln

Teaching, Learning and Teacher Education

PI: International Consortium for Multilingual Excellence in Education

This packet was designed and created by **Lacey Farmer**  
in collaboration with Tricia Gray and Alexa Yunes.



The Standards that Informed the Development of this Packet are:

CCSS.Math.Content.K.G.A.1

Describe objects in the environment using names of shapes, and describe the relative positions of these objects using terms such as above, below, beside, in front of, behind, and next to

CCSS.Math.Content.K.G.A.1

Correctly name shapes regardless of their orientations or overall size

CCSS.Math.Content.K.CC.A.2

Count forward beginning from a given number within the known sequence (instead of having to begin at 1)

CCSS.ELA-Literacy.W.K.2

Use a combination of drawing, dictating, and writing to compose informative/explanatory texts in which they are writing about and supply some information about the topic



**K – 1<sup>st</sup> grade • English Level 2**

# Learning Packet #5

Theme: Hygiene



# International Consortium for Multilingual Excellence in Education



August 15<sup>th</sup>, 2020

Dear Families:

During the COVID-19 pandemic, the academic classroom expanded into the home in new ways. Many students have limited access to technology, others struggle with online learning, and some simply want more to do while they are at home. With these things in mind, we have created an extensive resource of learning materials that we hope will be helpful for your children to engage with. These Activity Packets were designed with your students in mind and are aligned with each of their grade level content. Each activity in the packets will help students continue with their schooling as well as continue to grow their multilingualism. We encourage you to talk to your student about what they are doing and let your child ask you about the topics they are learning about. The packet is in English, but we encourage you and your children to speak and think together in any language you would like to. We strongly encourage you to use the language you feel most comfortable using with your student. Supporting their learning in all the languages they know is helpful—even for developing their English! So, please encourage your child to do the work in the packet in any language they would like.

We know that families are dealing with a lot of stress and uncertainty right now, so we encourage you to play the role you would like to play with your student and their Activity Packet based on what works best for you. We recommend reading the information about the packet and activities and then discussing with your student how the packet works and how they can work through it. We believe that with that introduction, your student can do a lot, if not all, of the work themselves. However, if you are available to work more closely with your child (or for a sibling or other family member to do so), we encourage that as well. Please know, this is not intended to be something that adds stress and work to your family during this demanding time. We hope that this is a helpful resource so your student can continue growing academically while in unusual situations.

We also hope you will find these packets interesting and fun. We have integrated activities from all of the grade level content standards: English Language Arts, Mathematics, Social Studies, Science, Physical Education and Art. We have also developed different packets for the different levels of English proficiency, so your child should feel challenged but also capable of largely understanding the content in front of them.

Kinder-5th grade students will create a Buddy for their packets. This is the first activity in the packets and is intended to give children have someone to talk to about the work they are doing in the packet. We have included images of “buddies” to choose from. Choose a buddy, personalize it, and even name the buddy. Throughout the packet activities, students will be told to talk to their buddy or even to ask their buddy questions. With this buddy, students can work independently without needing your time and attention to be successful with the packet. However, we also encourage your student to talk with you or other family members as they are available. Further, your student could pick a stuffed animal or doll or something else as their buddy. They don’t have to use one of the buddies we offer, but they should plan for who their buddy will be each time they work on the packet. This might be something they will need your help understanding.

# International Consortium for Multilingual Excellence in Education



In these packets, we have included the following activities:

- Dictionary. Each day we hope that your student will engage with words they find interesting and want to keep track of. We encourage students to use the dictionary activities to keep track of words they learn and find interesting. We also encourage students to use any language they would like as well as pictures to help them remember what the words mean.
- Reading and Writing. Each day, your student will engage in learning new words and using them through reading and writing. Students can write in any language and connect what they already know to English. There is also an opportunity for your student to write about whatever they would like that day.
- Mathematics. Each day, your student will also have the opportunity to practice early math skills like counting, addition, and subtraction.
- This specific packet focuses on good hygiene practices like washing hands, brushing teeth, and bathing. Other practices that help keep us healthy are also included such as sleep and exercise. Now more than ever, we need to educate children on how to keep themselves healthy.

We hope that these activities will enhance your child's learning while we work through these very unusual circumstances. We also hope that they will give your child opportunities for productive play. If you have any questions or concerns about these packets, feel free to reach out to our project at [icmee@unl.edu](mailto:icmee@unl.edu) or by calling the Teaching, Learning and Teacher Education department at 402-472-2231.

Sincerely,

Kara Mitchell Viesca, PhD

Associate Professor of Language Education

University of Nebraska Lincoln

Teaching, Learning and Teacher Education

PI: International Consortium for Multilingual Excellence in Education

This packet was designed and created by **Lacey Farmer** in collaboration with Tricia Gray and Alexa Yunes.



# International Consortium for Multilingual Excellence in Education



15 de agosto del 2020

Estimadas familias:

Durante la pandemia del COVID-19, ha sido necesario que los estudiantes aprendan en casa. Muchos de los estudiantes tienen acceso limitado a la tecnología, otros tienen dificultad para aprender en línea y algunos simplemente quieren tener algo más que hacer mientras están en casa. Pensando en estas razones, hemos creado un recurso con una gran extensión de materiales de aprendizaje que esperamos serán útiles para que sus hijos participen activamente. Estos paquetes de aprendizaje fueron diseñados teniendo en mente a sus niños y están alineados a los contenidos de cada nivel de grado. Cada actividad en estos paquetes los ayudará a continuar con su escolarización, así como a seguir aumentando su multilingüismo. Lo alentamos a que hable con su estudiante sobre lo que está haciendo y deje que le pregunte sobre los temas que le interesan. El paquete está en inglés, pero le recomendamos a usted y a su estudiante que hablen y piensen juntos en el idioma que deseen. Le recomendamos encarecidamente que use el idioma con el que se sienta más cómodo al comunicarse con su estudiante, ya que respaldar su aprendizaje en todos los idiomas que sabe es útil, ¡incluso para su inglés! Por lo tanto, anime a su estudiante a hacer el trabajo en el paquete en cualquier idioma que desee.

Sabemos que las familias están lidiando con mucho estrés e incertidumbre en este momento, por lo que lo alentamos a que desempeñe el papel que le gustaría desempeñar con su estudiante y su paquete de actividades según lo que funcione mejor para usted. Le recomendamos leer la información sobre el paquete y las actividades que contiene y luego discutir con su estudiante cómo funciona el paquete y cómo pueden trabajar en él. Creemos que, con esa introducción, su estudiante puede hacer mucho, si no todo, el trabajo por sí mismo. Sin embargo, si usted está disponible para trabajar más estrechamente con su estudiante (o un hermano u otro miembro de la familia), también lo recomendamos. Por favor, tenga en cuenta que esto no pretende ser algo que agregue estrés y trabajo a su familia durante este momento tan desgastante. Por el contrario, esperamos que este sea un recurso útil para que su estudiante pueda continuar desarrollándose académicamente durante esta situación tan inusual.

También esperamos que ustedes encontrarán estos paquetes interesantes y divertidos. Hemos integrado actividades de todos los estándares de contenido de nivel de grado: Artes del Lenguaje en inglés, Matemáticas, Estudios Sociales, Ciencias, Educación Física y Arte. También hemos desarrollado diferentes paquetes para los diferentes niveles de dominio del inglés, de esta manera su hijo podrá sentir el desafío y también será capaz de comprender en gran medida el contenido que se les presenta.

Los estudiantes de Kínder a 5to grado crearán un Amigo para su paquete. Esta es la primera actividad en el paquete y está destinada a ayudar a su estudiante a tener a alguien con quien hablar sobre el trabajo que está haciendo en el paquete. Hemos incluido imágenes de posibles "amigos" para que su estudiante puede elegir. Sugerimos que elijan un amigo, lo personalicen e inclusive le pongan un nombre. A lo largo de las actividades del paquete, se le pedirá a su estudiante que hable con su amigo o incluso que le haga preguntas. Con este compañero, su estudiante podrá trabajar de forma independiente sin necesidad de su tiempo y atención para tener éxito al trabajar en el paquete.

ICMEE is housed within:



# International Consortium for Multilingual Excellence in Education



Sin embargo, también alentamos a su estudiante a hablar con usted u otros miembros de la familia cuando estén disponibles. Además, su estudiante puede elegir un animal de peluche o muñeca o alguien más como su amigo. No tienen que usar uno de los amigos que ofrecemos, pero deben planificar quién será su amigo cada vez que trabajen en el paquete (uno de nuestros amigos, alguien en su familia / hogar, una muñeca que ya tienen, etc.). Esto podría ser algo en lo que necesitarán su ayuda para poder comprender.

En este paquete hemos incluido las siguientes actividades:

- **Diccionario:** Esperamos que cada día su estudiante capte palabras que encontrará interesantes y querrá tener un seguimiento y registro de estas. Al final de los paquetes encontrarán páginas en las que su estudiante podrá mantener su propio diccionario. Recomendamos ampliamente que los estudiantes usen estas páginas para registrar palabras que les gusten o les parezcan interesantes. También alentamos a los estudiantes a usar cualquier lenguaje que deseen, así como imágenes para recordar el significado de las palabras.
- **Leyendo y escribiendo:** Cada día, su estudiante se dedicará a aprender nuevas palabras y usarlas a través de la lectura y la escritura. Los estudiantes pueden escribir en cualquier idioma y conectar lo que ya saben al inglés. También habrá oportunidades para que su estudiante escriba sobre lo que desee ese día.
- **Matemáticas:** Cada día, su estudiante también tendrá la oportunidad de practicar habilidades matemáticas tempranas como contar, sumar y restar.
- **Este paquete específico se enfoca en buenas prácticas de higiene como lavarse las manos, cepillarse los dientes y bañarse. También se incluyen otras prácticas que nos ayudan a mantenernos saludables como el sueño y el ejercicio. Ahora más que nunca, necesitamos educar a los niños sobre cómo mantenerse saludables.**

Esperamos que estas actividades mejoren el aprendizaje de su hijo mientras trabajamos juntos para atravesar estas circunstancias tan inusuales. También esperamos que le darán a su hijo oportunidades de juego productivo. Si tiene alguna pregunta o inquietud acerca de estos paquetes, siéntase en libertad de comunicarse con nuestro proyecto a [icmee@unl.edu](mailto:icmee@unl.edu) o llamando al departamento de Enseñanza, Aprendizaje y Educación para maestras (Teaching, Learning, and Teacher Education) al 402-472-2231.

Sinceramente,

Kara Mitchell Viesca, PhD  
Associate Professor of Language Education  
University of Nebraska Lincoln  
Teaching, Learning and Teacher Education  
PI: International Consortium for Multilingual Excellence in Education  
ICMEE is housed within:





## Share your learning!

Share a picture of any of your work by using **#MultilingualProud** on social media.

We'd love to see what you've done with this packet!





## Instructions Key



- Share with someone else
- Comparte con alguien más
- مشاركتها مع شخص آخر
- La wadaag qof
- Chia sẻ với ai đó



- Read
- Lee
- اقرأ
- Akhriso
- Đọc



- Write
- Escribe
- اكتب
- Qor
- Viết



- Sort
- Ordena
- رتب
- Kala sooc
- lựa chọn



- Move your body
- Mueve tu cuerpo
- حرك جسمك
- Dhaqdhaqaaqa jirkaaga
- Di chuyển cơ thể của bạn



- Cut
- Corta
- قص الورقة
- Waraaqda jar
- Cắt giấy



- Read out loud
- Lee en voz alta
- قراءة بصوت عال
- Kor u aqri
- Đọc to



- Make a connection
- Hacer una conexión
- إجراء اتصال
- Xiriir samee
- Tạo kết nối

123

- Count
- Cuenta
- العدد
- Tiri
- đếm



- Draw
- Dibuja
- رسم
- Sawir
- Vẽ tranh



- Find
- Encuentra
- وجد
- Soo hel
- Tìm thấy



- Color
- Colorea
- لون
- Midab gudaha
- làm cho hoa mỹ



- Share with your Buddy
- Comparte con tu Buddy
- شارك مع صديقك
- La wadaag asxaabtaada
- Chia sẻ với bạn bè của bạn



# Day 1

# My Buddy

1. Choose a Buddy

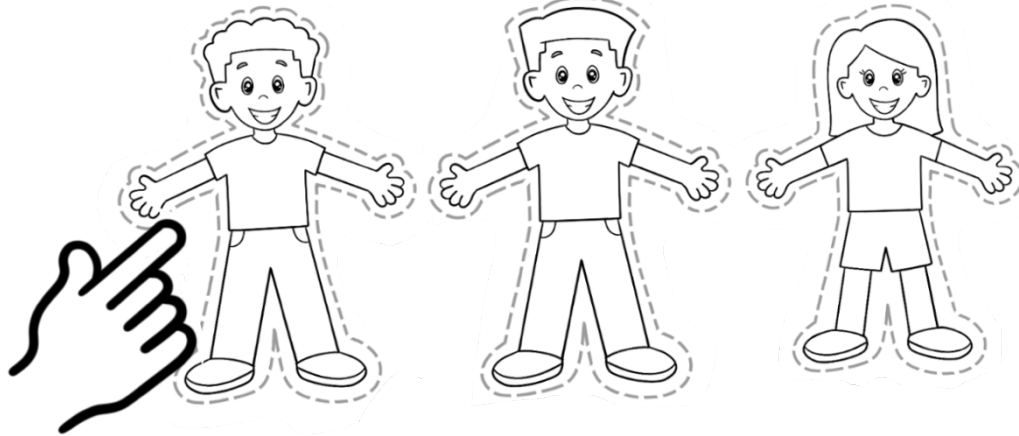

2.

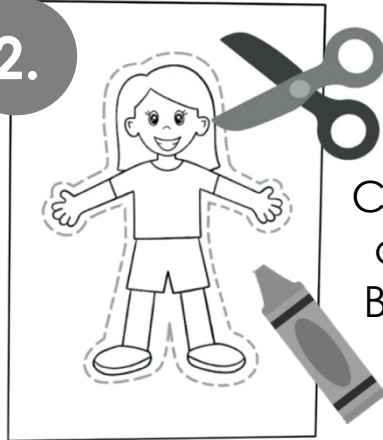

Cut out and color your Buddy and give it a name!

3.

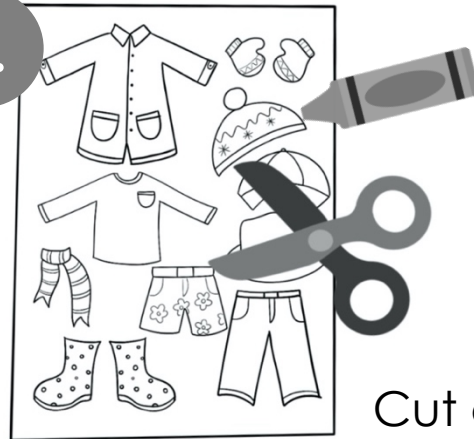

Cut out and color the accessories

4.



Have fun with your Buddy!  
Dress them up, play with them, and even talk with them!

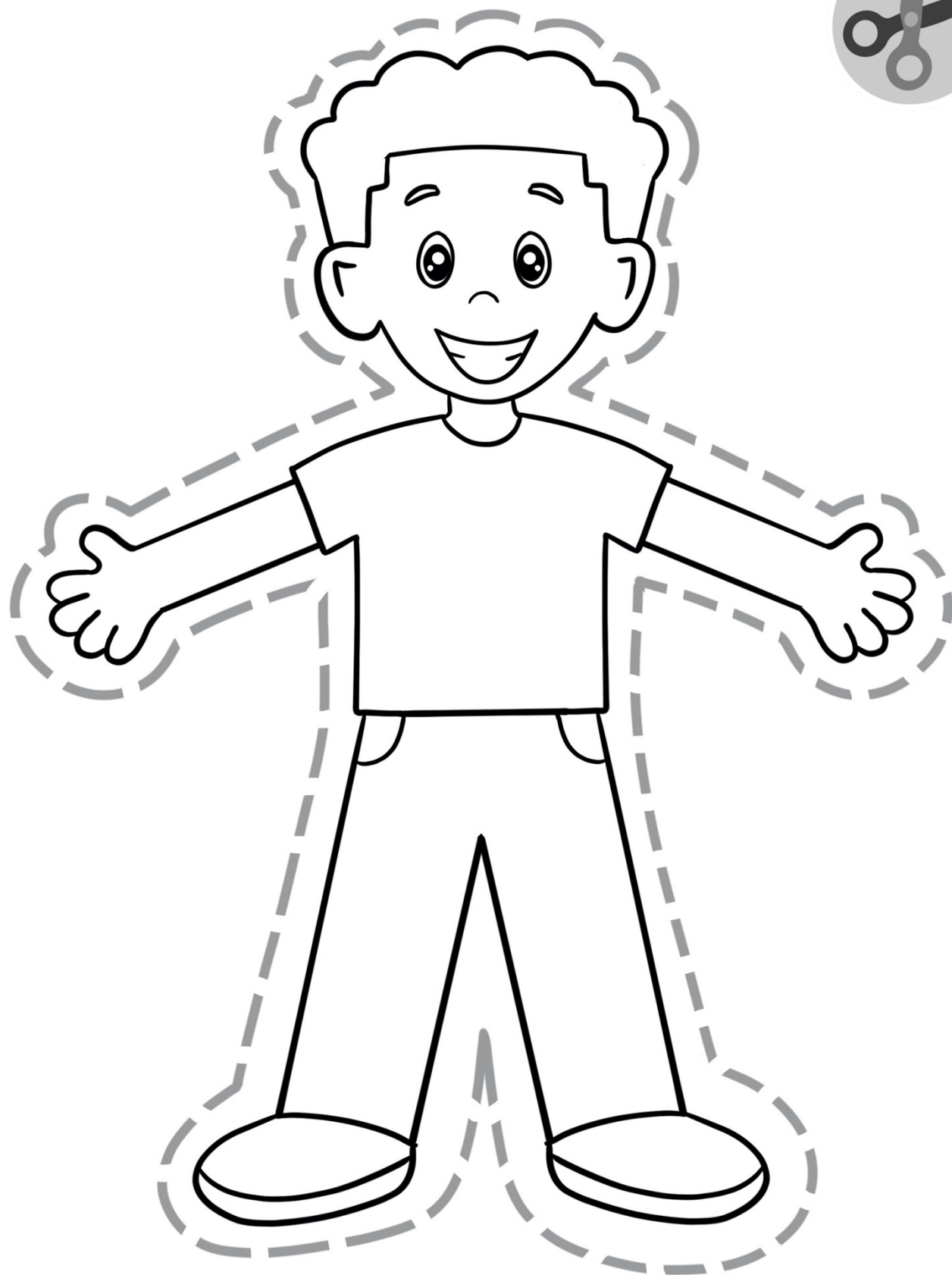

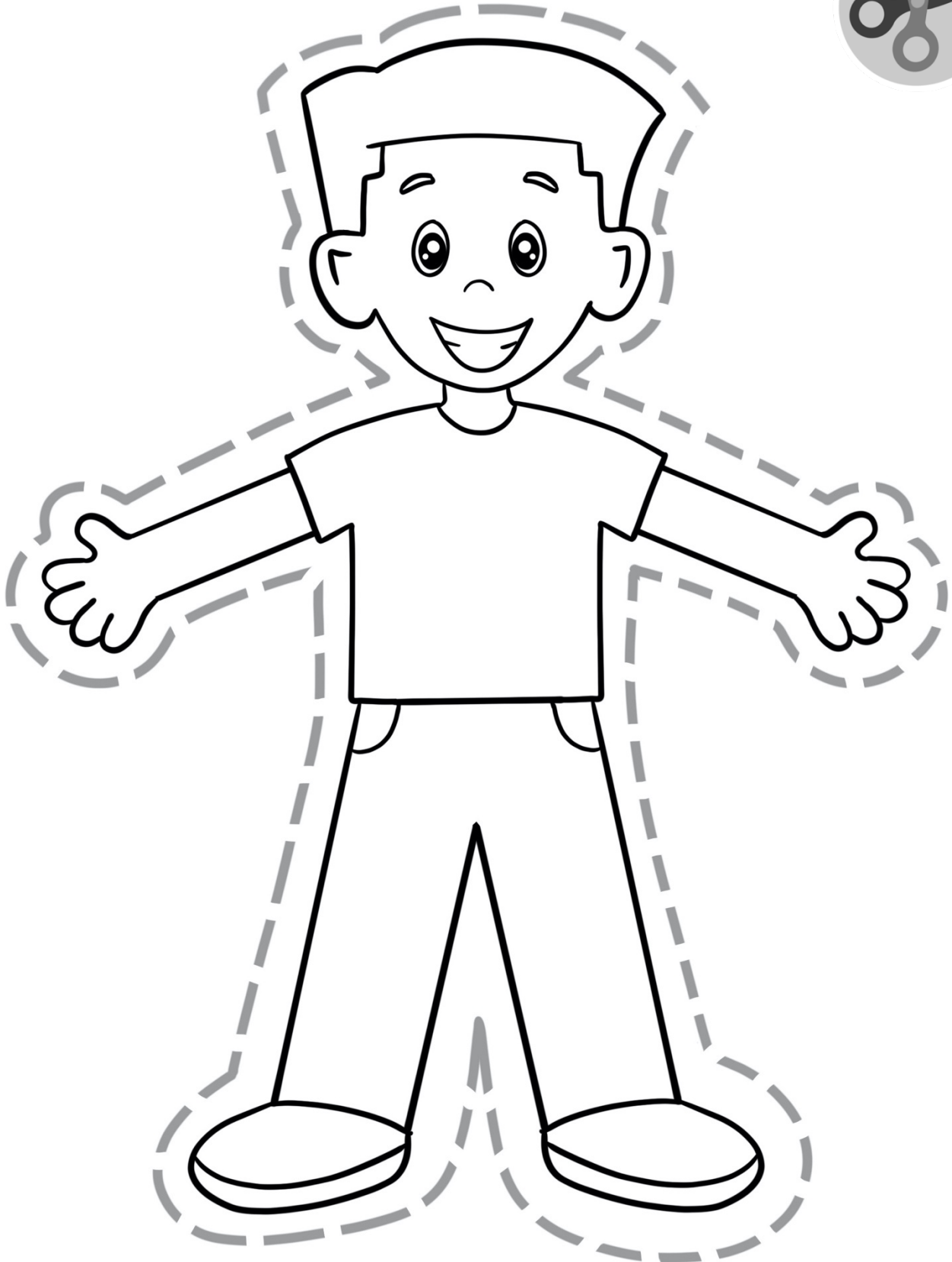

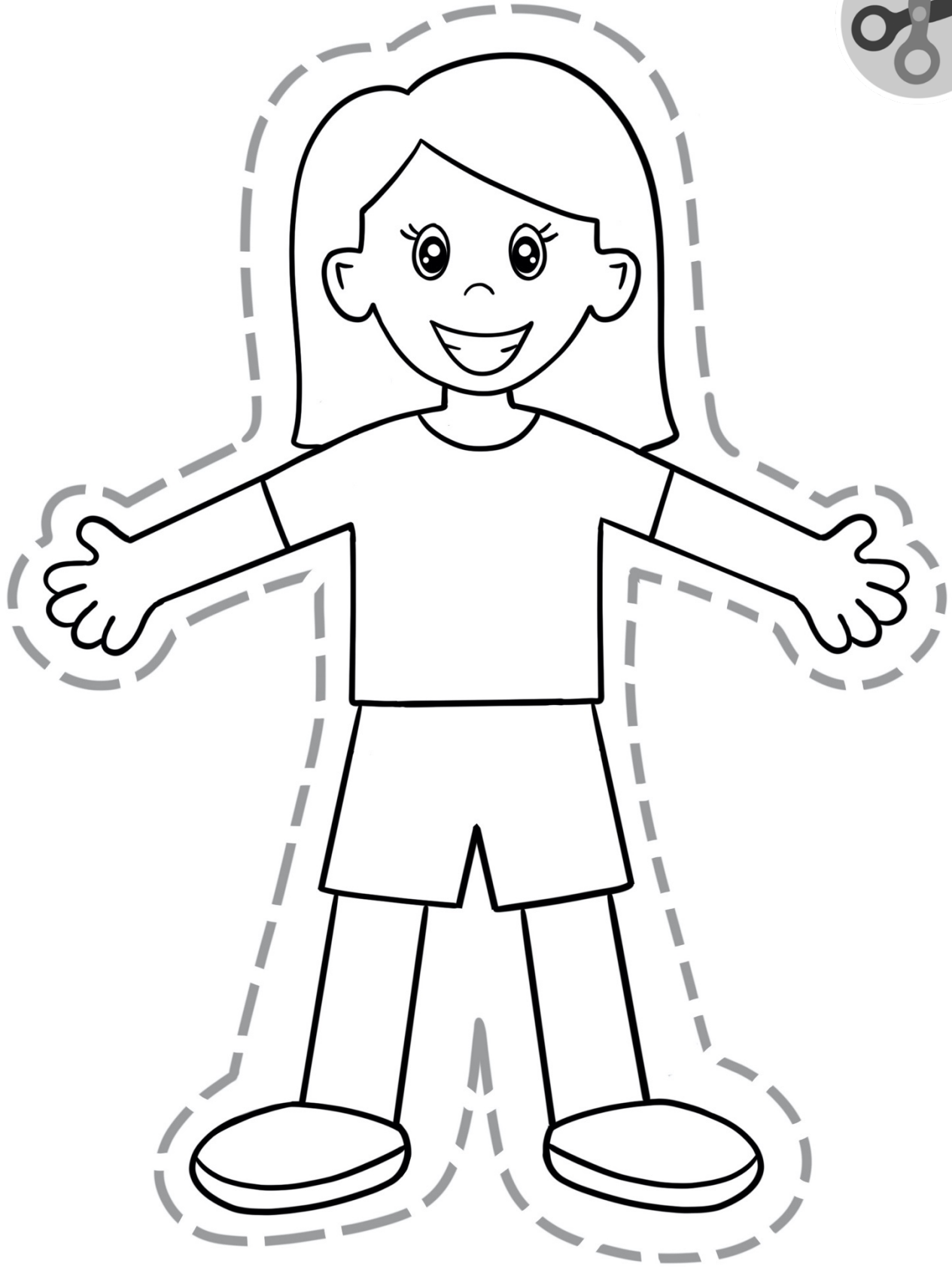

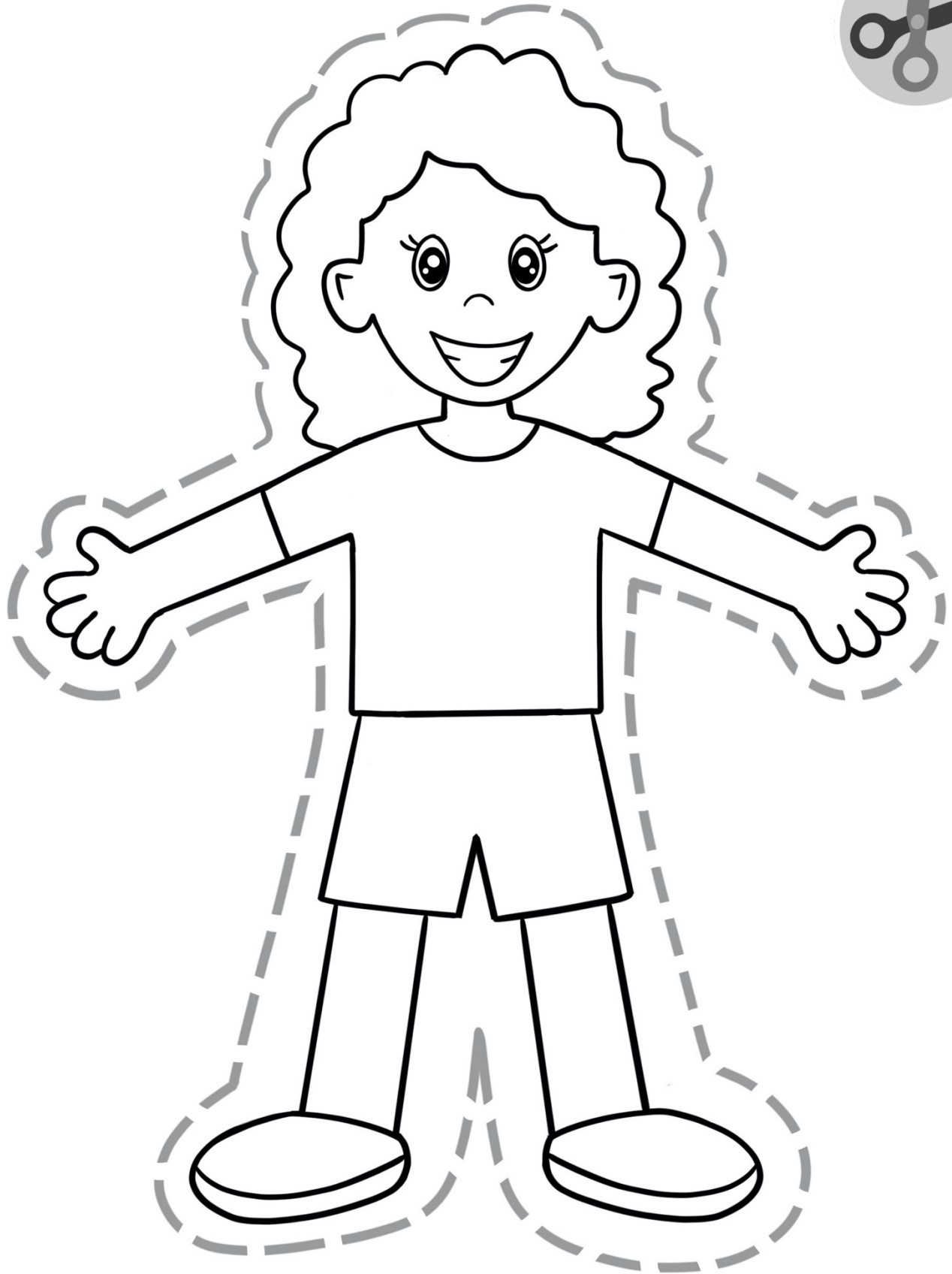



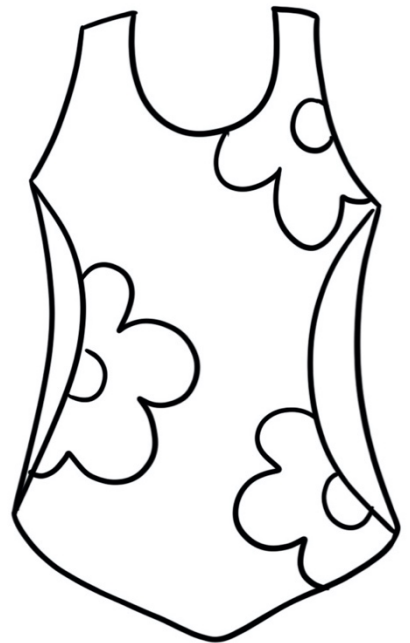
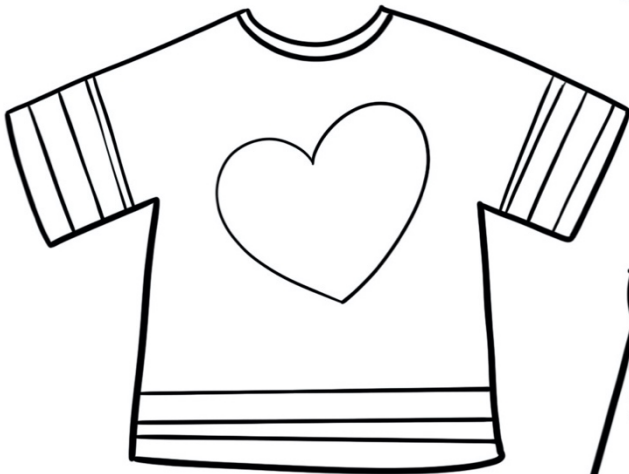
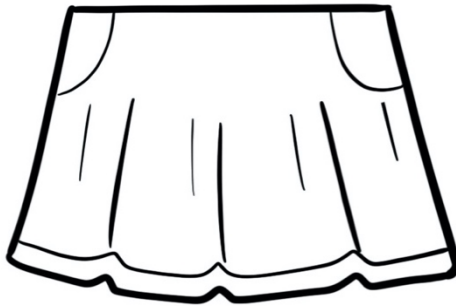
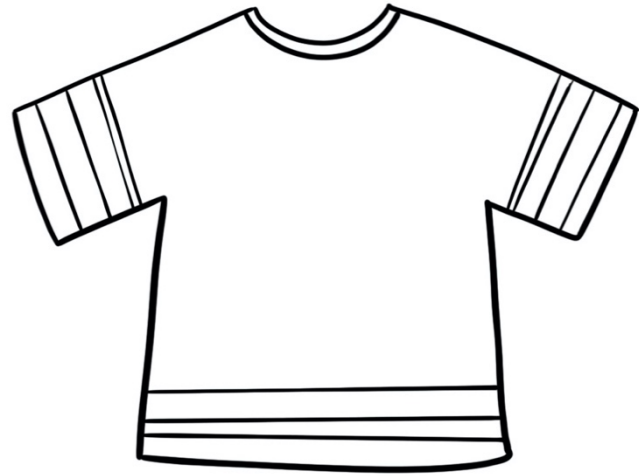
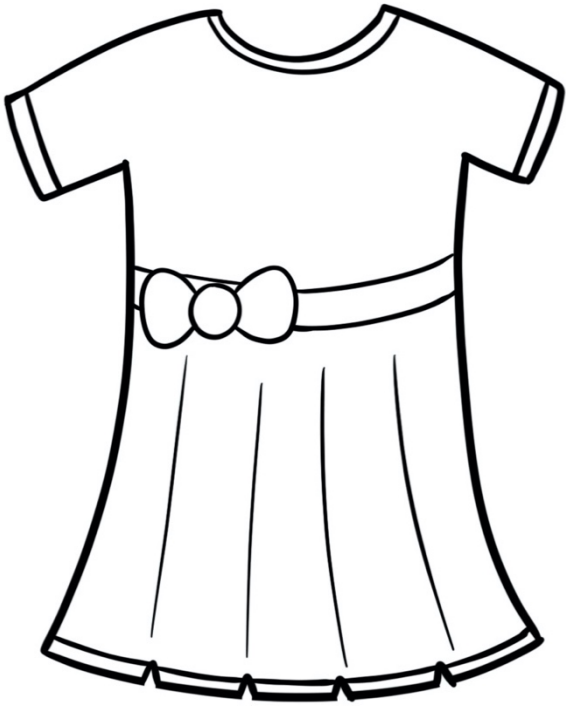

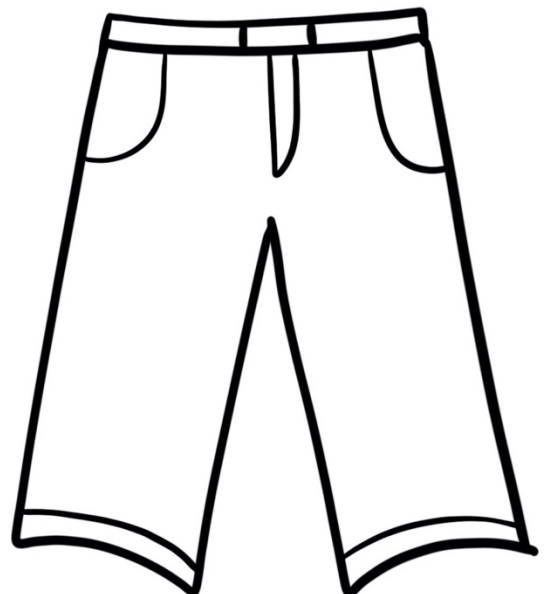
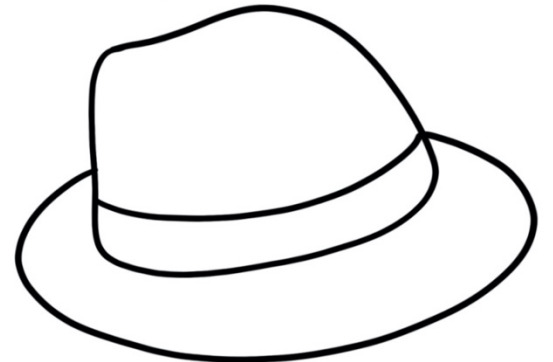
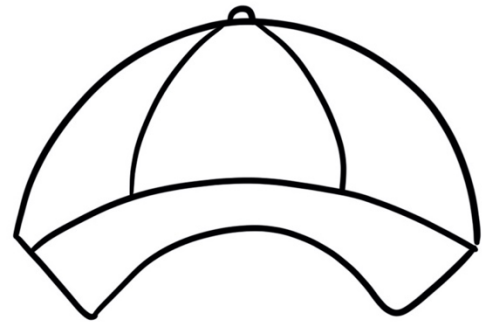
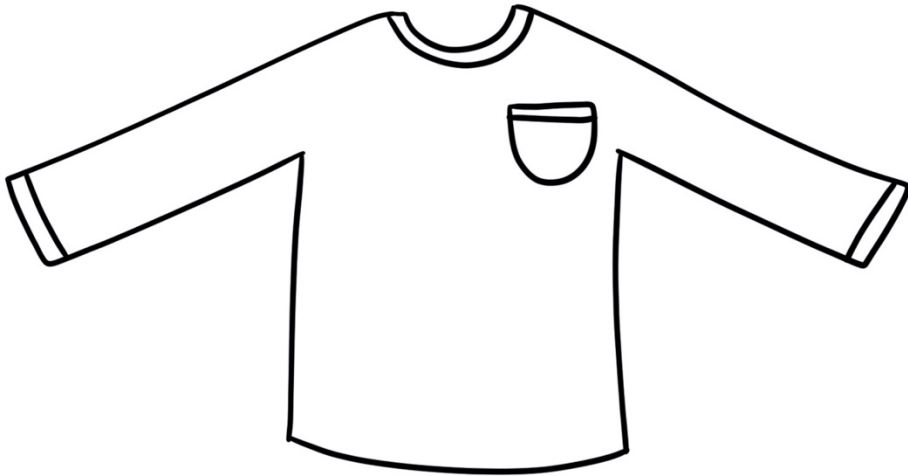

# Day 1



Hi! My name is  
Kyla! I am going  
to help you.

1



Learning New Words

2



Germs are Everywhere!

3



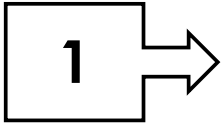

Washing Our Hands



## Learning New Words

For each new word,

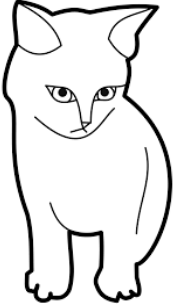
- 1 Look at the picture.
- 2 Write or draw in your language.
- 3 Trace the word in English.
- 4 Write the word three times.

<p>1</p> <p>cat</p> 	<p>3</p> <p>cat</p>
<p>2</p>  <p>paka</p>	<p>4</p> <p>cat</p> <p>cat</p> <p>cat</p>



Now you try!

<p>1</p> 	<p>3</p> <p>wash</p> <p>4</p>
<p>2</p>	<p>4</p>

<p>1</p> 	<p>3</p> <p>soap</p> <p>4</p>
<p>2</p>	<p>4</p>

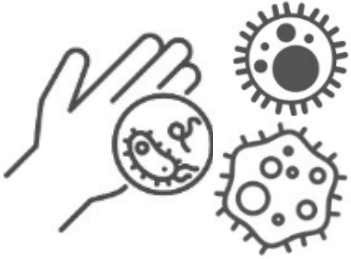
<p>1</p>  <p>2</p>	<p>3</p> <p>germs</p> <p>4</p> <p>Blank handwriting lines for practice.</p>
---	---

<p>1</p>  <p>2</p>	<p>3</p> <p>bathroom</p> <p>4</p> <p>Blank handwriting lines for practice.</p>
---	--

2 →

## Germs are Everywhere!

Germs are everywhere!  
Everything we touch puts  
germs on our hands.

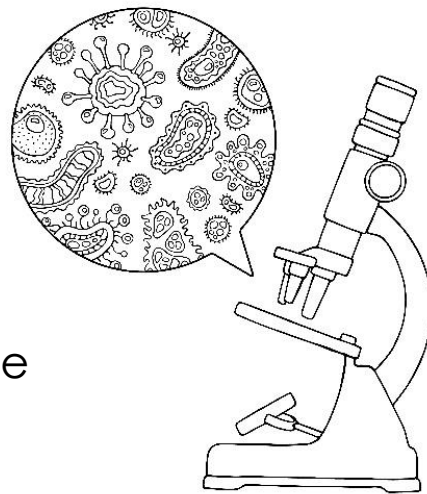
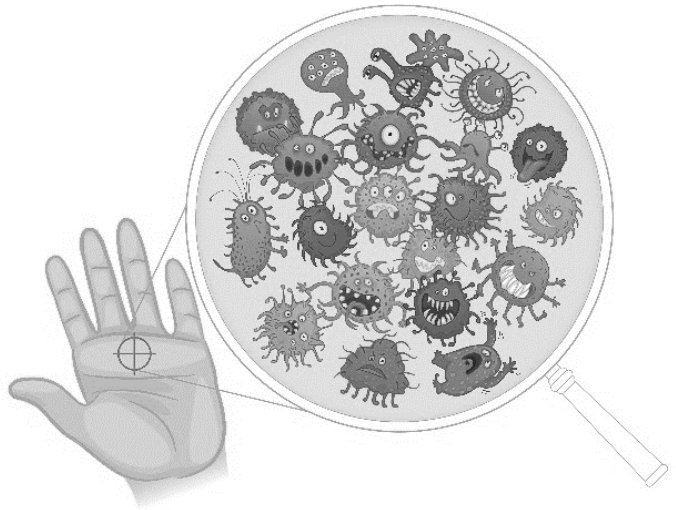

Scientists can see  
germs with a  
microscope.





Germs can make us sick.



The best way to stay healthy is to wash our hands.

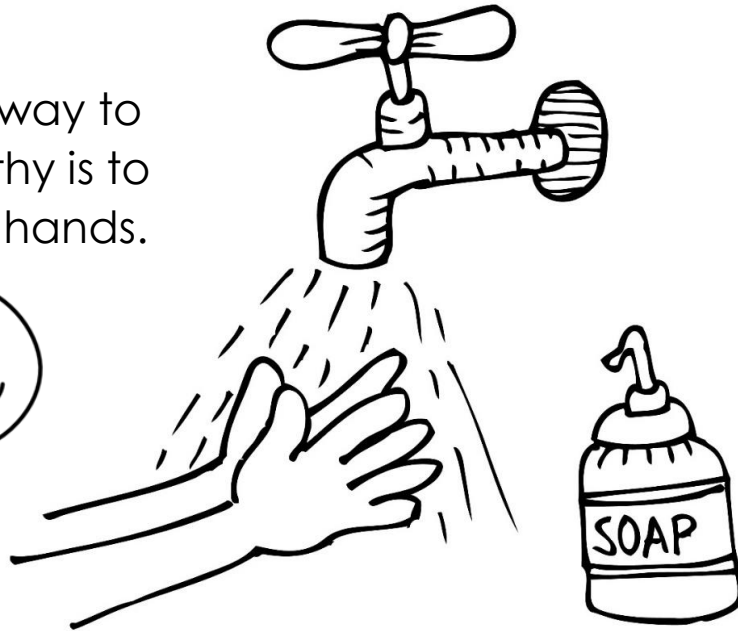



Sometimes we need to wash our hands AFTER an activity.

Sometimes we need to wash our hands BEFORE an activity.



dirty



food



wet



others



bloody





Cut out the pictures and glue, tape, or place them in the boxes on the next page.

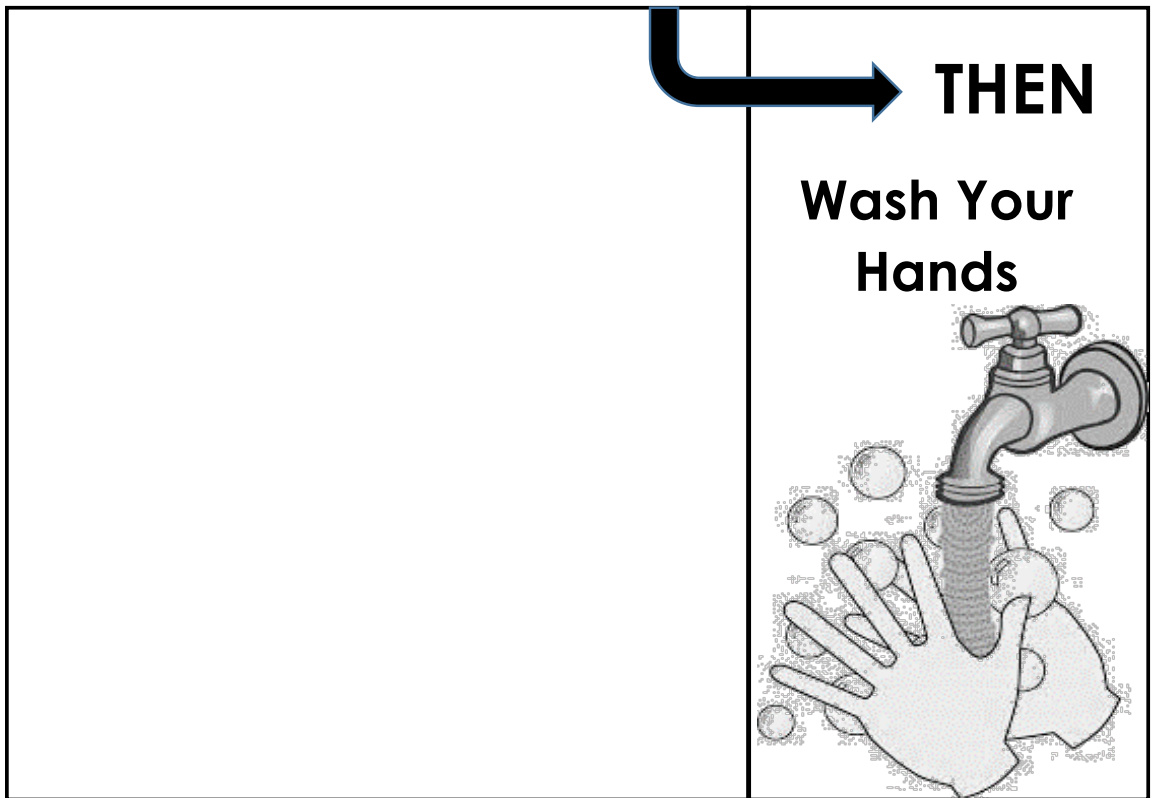
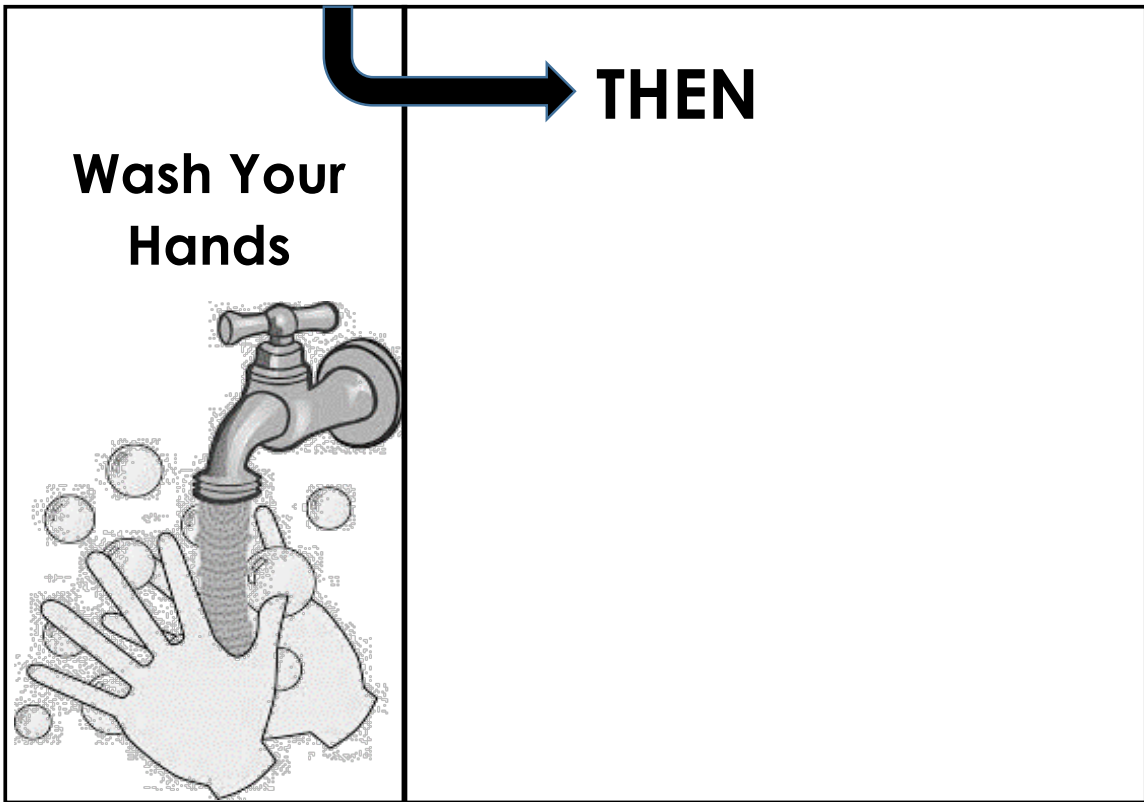

3



# Washing Our Hands

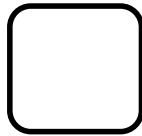
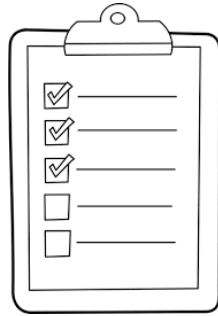

1. Tell your buddy how and when to wash hands.

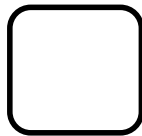

2. Teach two people how and when to wash their hands.

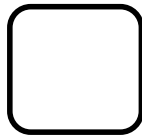

3. Put handwashing posters in bathrooms and the kitchen.

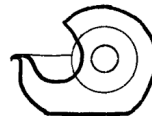

# Wash Your Hands

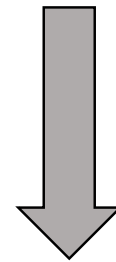
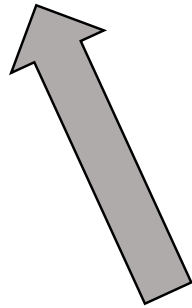
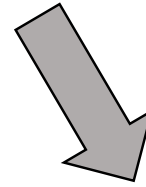

Count to 30

"1, 2, 3, 4, 5..... 30"



# Wash Your Hands

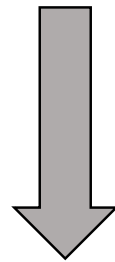
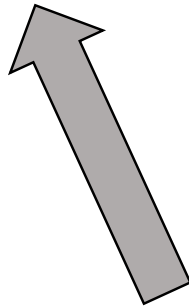
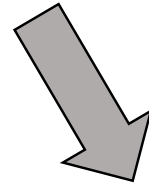

Count to 30

"1, 2, 3, 4, 5..... 30"





# Wash Your Hands

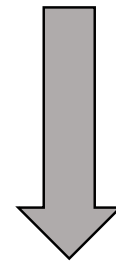
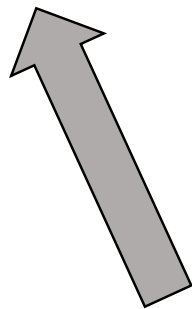
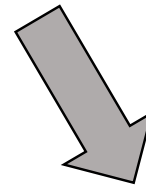

Count to 30

"1, 2, 3, 4, 5..... 30"



# Day 2

4



Brush Your Teeth

5



Toothbrush Subtraction

6





Toothbrush Tracking

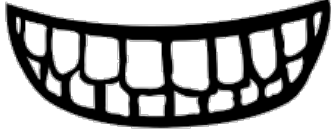
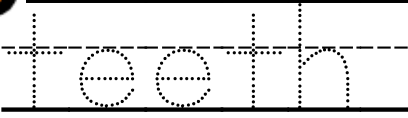
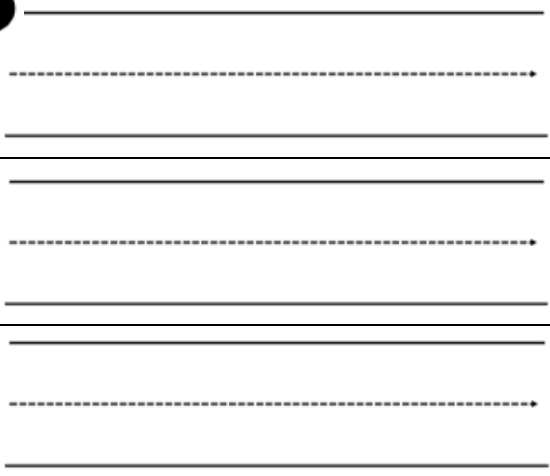

Start with today's new words.

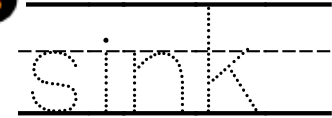
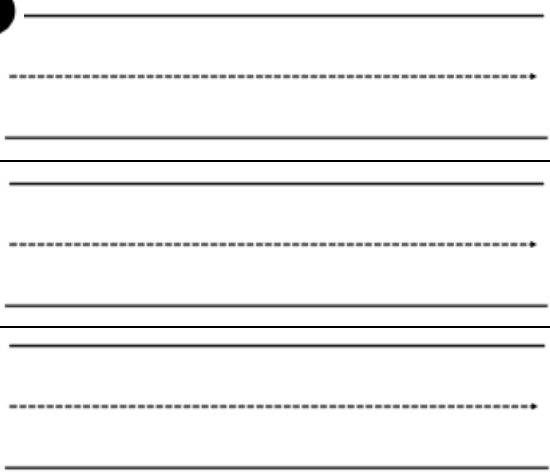
<p>1</p> 	<p>3</p> 
<p>2</p>	<p>4</p> 

<p>1</p> 	<p>3</p> 
<p>2</p>	<p>4</p> 

<p>1</p> 	<p>3</p> <p>toothbrush</p>
<p>2</p>	<p>4</p> <p>Blank handwriting lines for practice</p>

<p>1</p> 	<p>3</p> <p>toothpaste</p>
<p>2</p>	<p>4</p> <p>Blank handwriting lines for practice</p>

4



## Brush Your Teeth



Germs are also  
on your teeth.

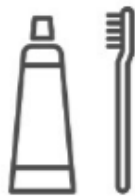
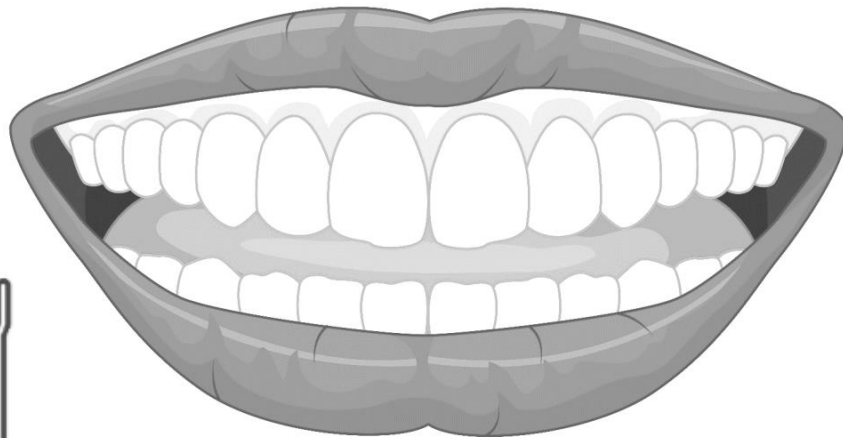
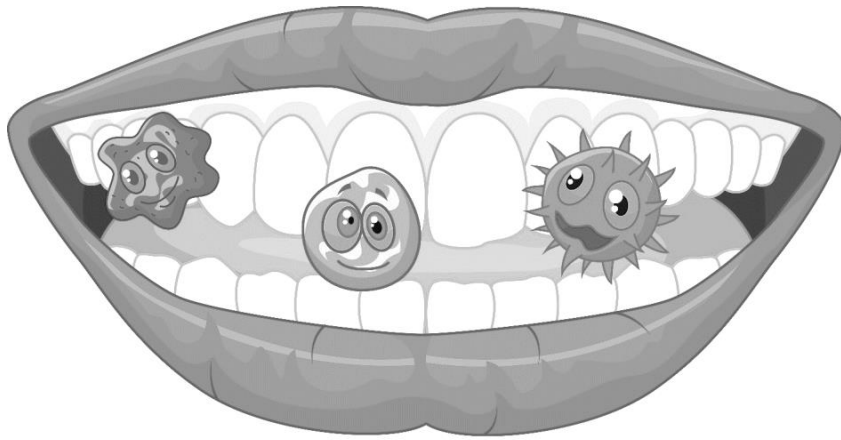
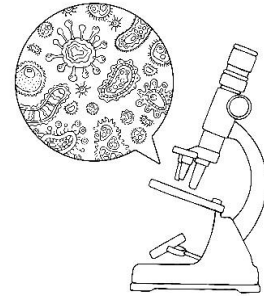

You can keep your teeth healthy by brushing them!

# Why?

Because

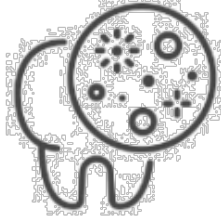

Germs on teeth can make them sick.



# When?



In the morning.



Before bed.

# How?



## HOW TO BRUSH YOUR TEETH



USE A SMALL AMOUNT OF TOOTHPASTE

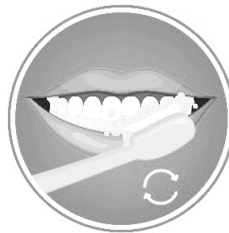

BRUSH THE OUTSIDE SURFACE OF ALL TEETH USING CIRCULAR MOTION

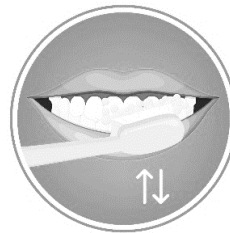

BRUSH THE OUTER SURFACE OF ALL TEETH USING UP AND DOWN MOTION

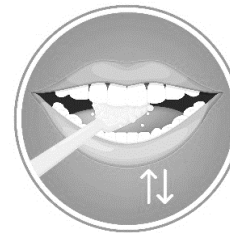

REPEAT FOR INNER SURFACE OF ALL TEETH

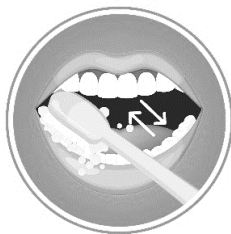

BRUSH THE CHEWING SURFACE OF ALL TEETH

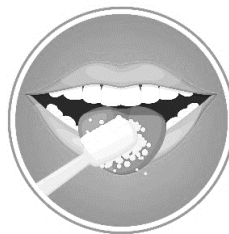

BRUSH THE TONGUE

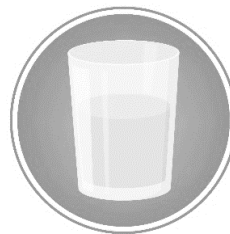

RINSE OUT YOUR MOUTH USING WATER

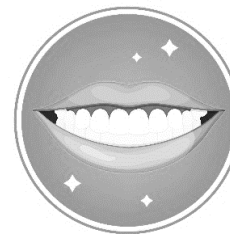

CONGRATULATIONS!

# 5 → Toothbrush Subtraction

- 1 Put the number of germs in the mouth.

5 - 2 = \_\_\_\_\_

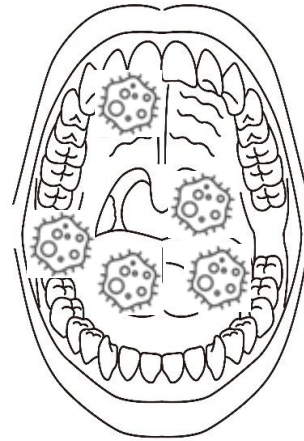

- 2 Use the toothbrush to brush some germs away.

5 - 2 = \_\_\_\_\_

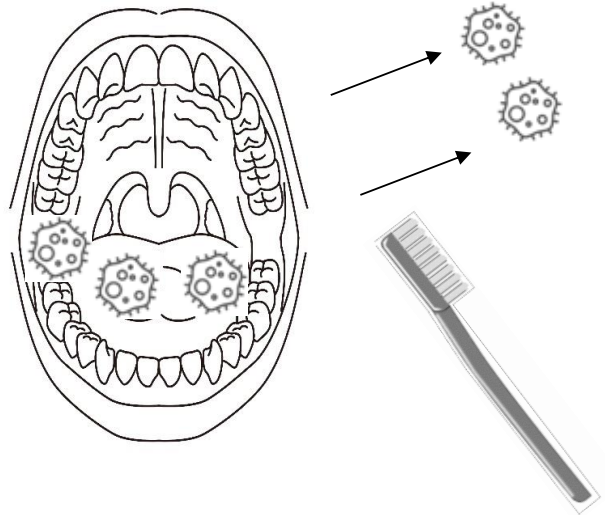

- 3 Write how many germs are left.

5 - 2 = 3

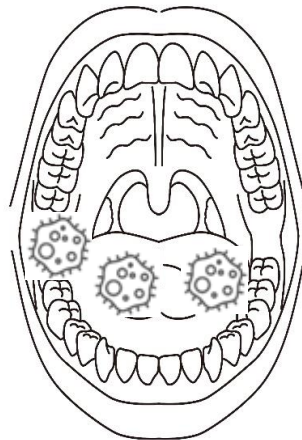

$7 - 3 = \underline{\quad}$

$11 - 5 = \underline{\quad}$

$13 - 9 = \underline{\quad}$

$16 - 3 = \underline{\quad}$

$19 - 10 = \underline{\quad}$

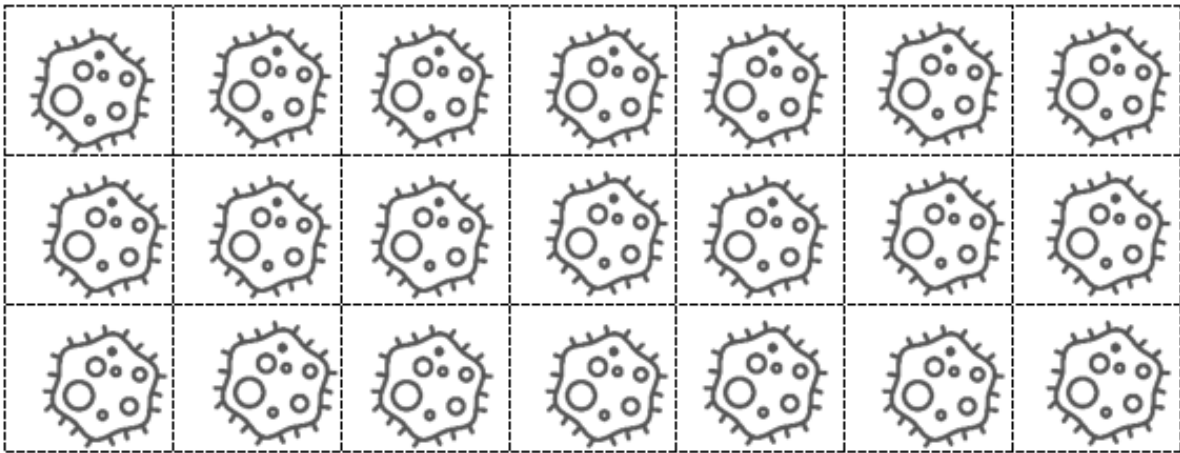



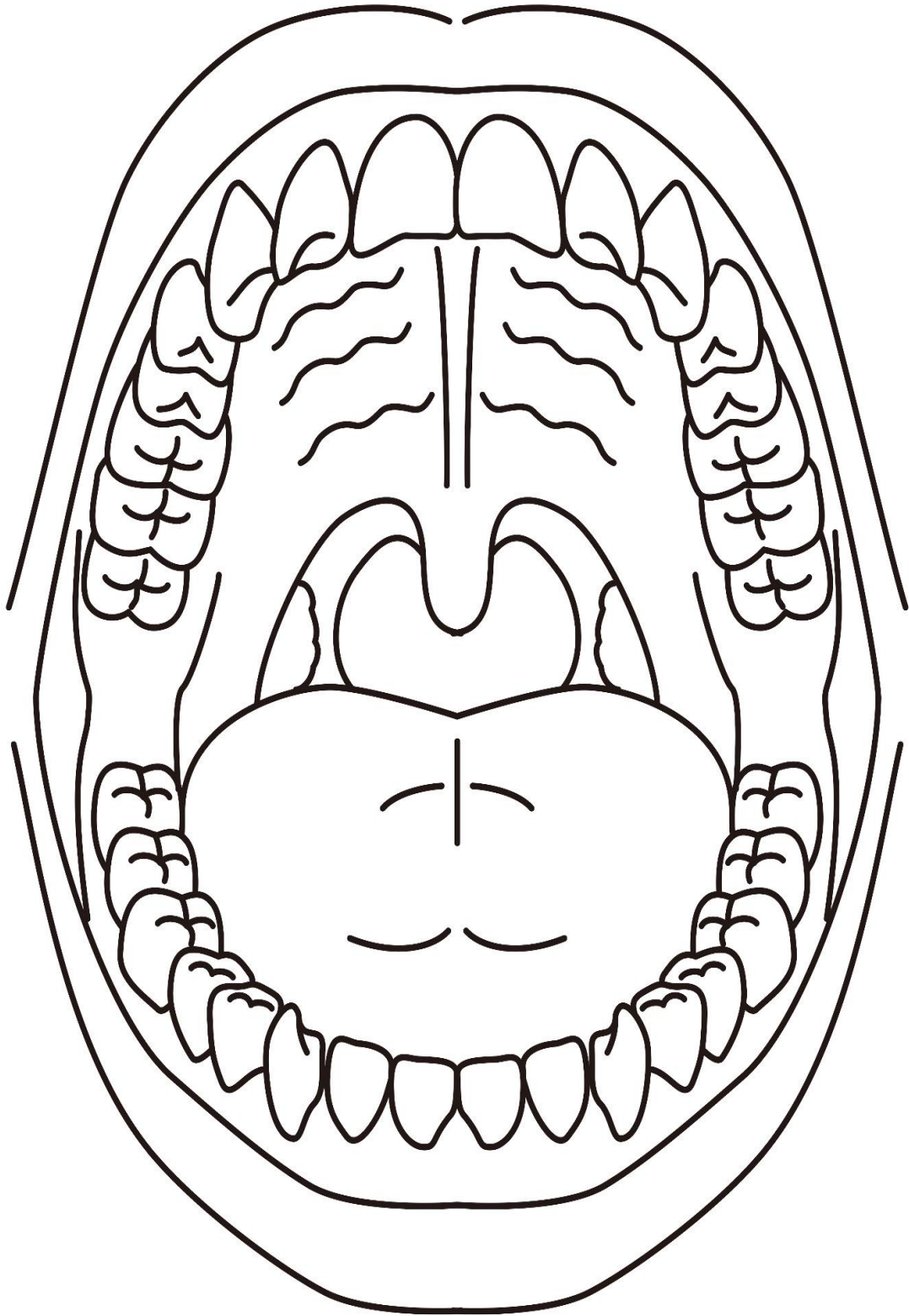



Now it's your turn to make your own subtraction problems



$$\underline{\hspace{2cm}} - \underline{\hspace{2cm}} = \underline{\hspace{2cm}}$$

$$\underline{\hspace{2cm}} - \underline{\hspace{2cm}} = \underline{\hspace{2cm}}$$

$$\underline{\hspace{2cm}} - \underline{\hspace{2cm}} = \underline{\hspace{2cm}}$$

$$\underline{\hspace{2cm}} - \underline{\hspace{2cm}} = \underline{\hspace{2cm}}$$

$$\underline{\hspace{2cm}} - \underline{\hspace{2cm}} = \underline{\hspace{2cm}}$$

$$\underline{\hspace{2cm}} - \underline{\hspace{2cm}} = \underline{\hspace{2cm}}$$

$$\underline{\hspace{2cm}} - \underline{\hspace{2cm}} = \underline{\hspace{2cm}}$$









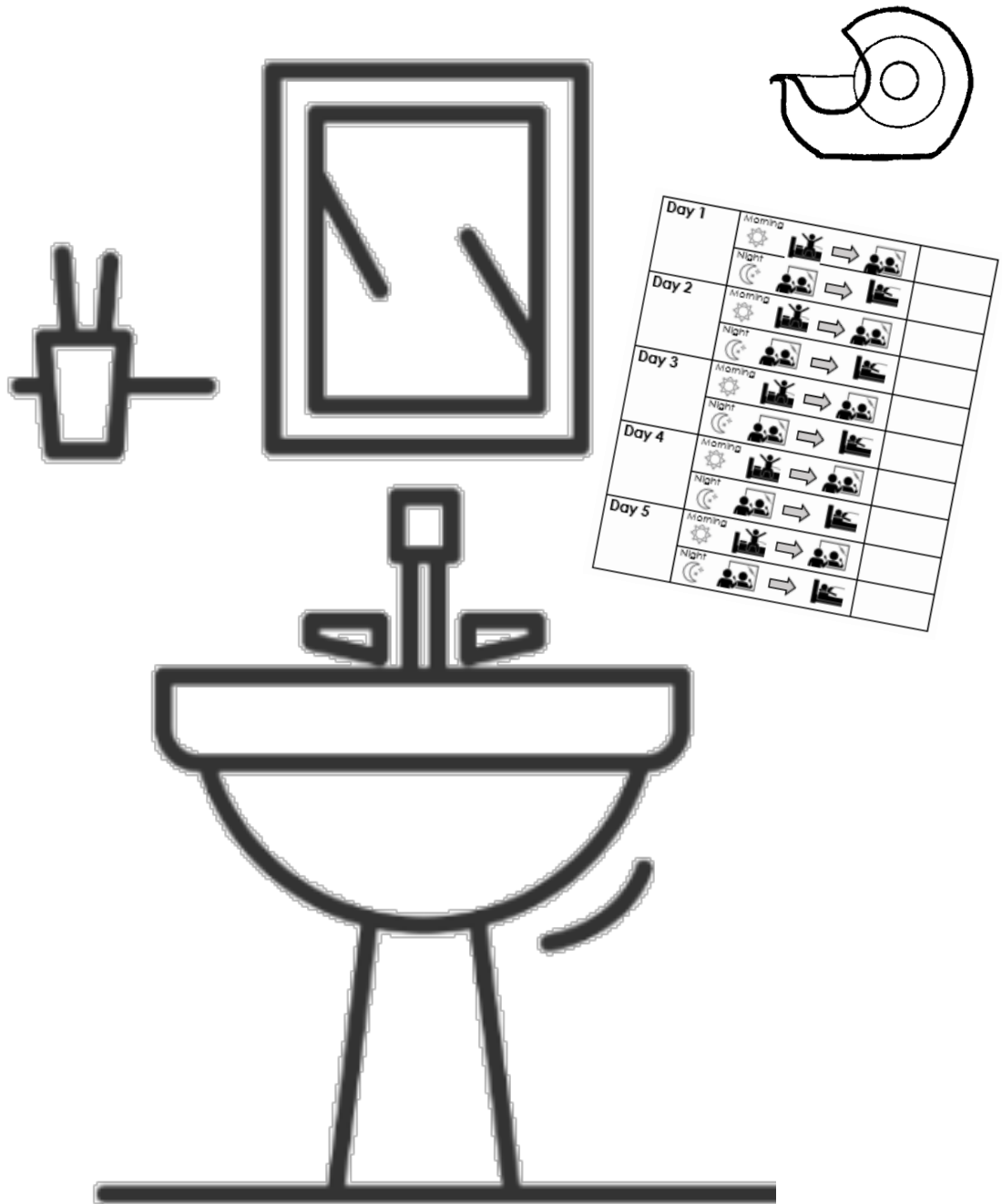











$$\underline{\hspace{2cm}} - \underline{\hspace{2cm}} = \underline{\hspace{2cm}}$$

# 6 →































## Toothbrush Tracking

Tear out the tracking sheet on the next page. Keep it in the bathroom and track your brushing for the next 5 days. You should brush in the morning and again at night.



Day	Morning	Night	
Day 1	 	 	
Day 2	 	 	
Day 3	 	 	
Day 4	 	 	
Day 5	 	 	



<b>Day 1</b>	Morning   → 	
	Niaht   → 	
<b>Day 2</b>	Morning   → 	
	Niaht   → 	
<b>Day 3</b>	Morning   → 	
	Niaht   → 	
<b>Day 4</b>	Morning   → 	
	Niaht   → 	
<b>Day 5</b>	Morning   → 	
	Niaht   → 	

# Day 3

7 → Healthy Habits

8 → Time

9 → Today's Number



Start with today's new words.

<p>1</p> 	<p>3</p> <p>oath</p>
<p>2</p>	<p>4</p> <p>Blank handwriting lines for the word 'oath'.</p>

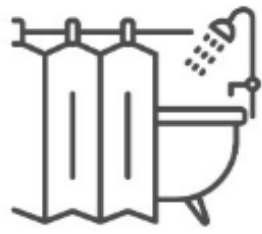
<p>1</p> 	<p>3</p> <p>shower</p>
<p>2</p>	<p>4</p> <p>Blank handwriting lines for the word 'shower'.</p>

7 →

# Healthy Habits



The last step to keeping yourself clean is regular showers and baths.

You can choose a shower or a bath.



Wash yourself several times a week.



Use soap and shampoo.



Wash your hair, body, face, and feet.



Draw a ✓ on the clean habits. 😊  
Draw a ✗ on the unclean habits. ☹️





8



# Time



We use clocks to help us tell time.

There are two types of clocks.

Digital  
Clocks



Analog  
Clocks



Look around your home.

How many digital clocks can you find?

How many analog clocks can you find?

The numbers on digital clocks might look a little different than the numbers we are used to seeing.

They are made by coloring parts of a seven-section template.

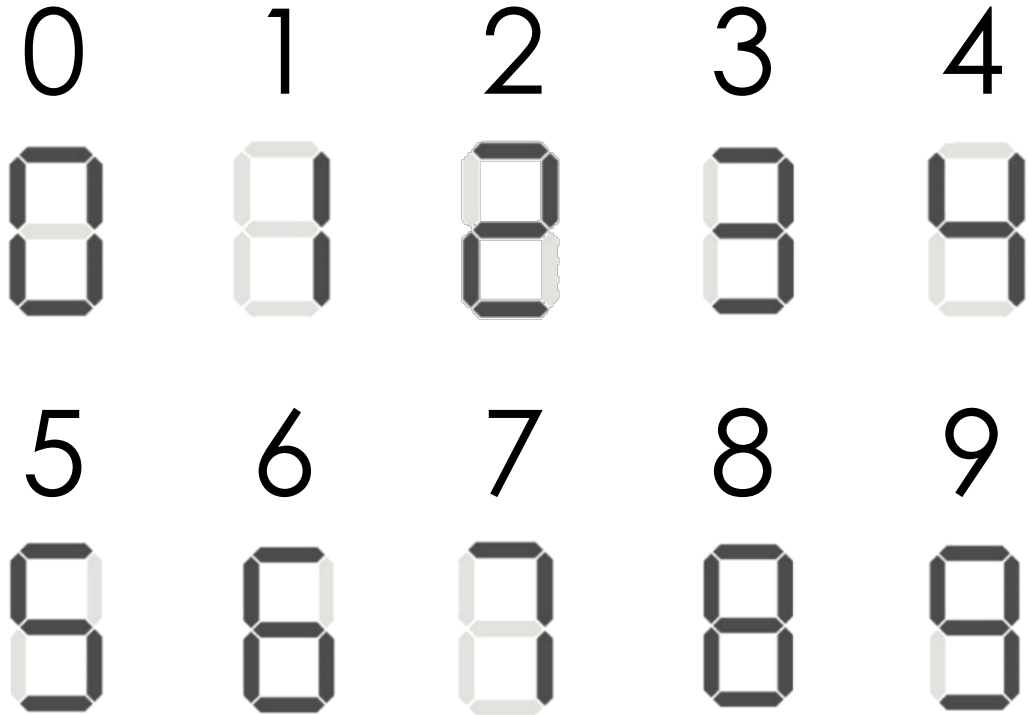

You try a few!



2		5		4	
6		7		0	



The large hand points to the minutes. When it points to the 12, that means 00 minutes.

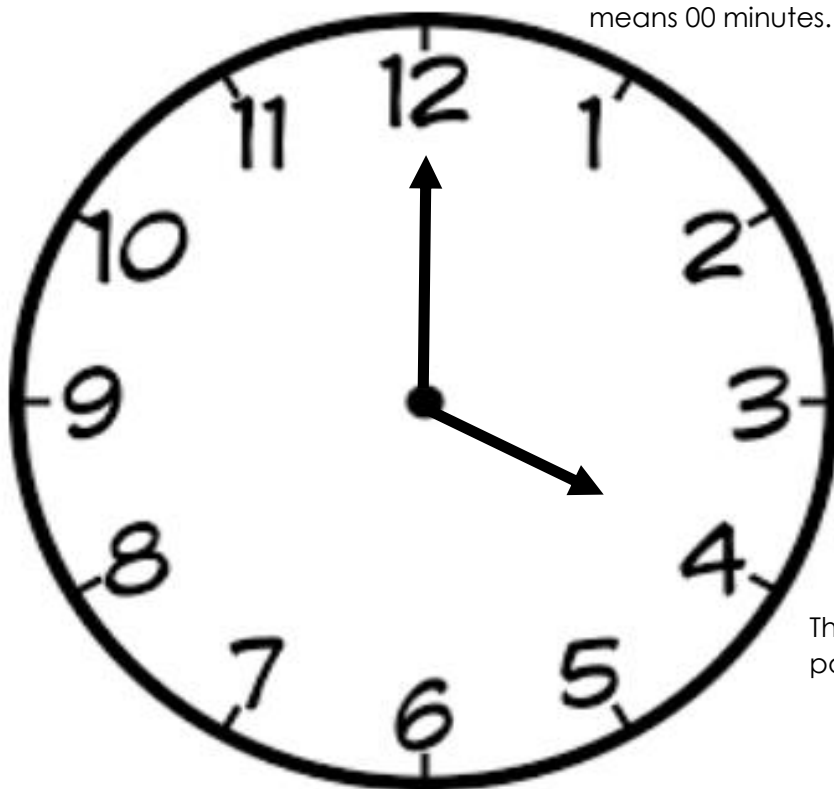

The small hand points to the hour.

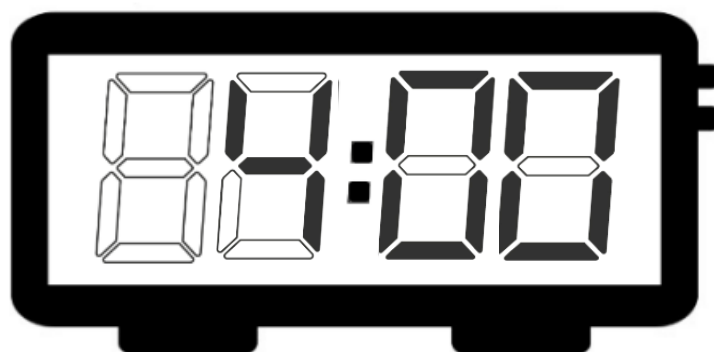

hour

minutes

We say, "four o'clock."



Match the analog clock to the digital clock.

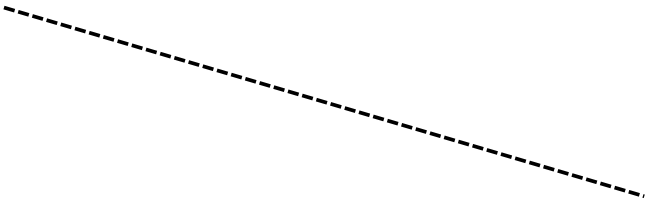
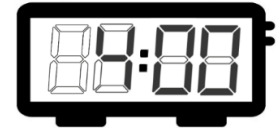
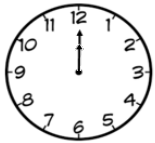
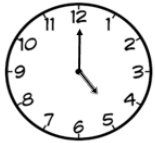
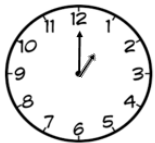
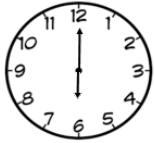
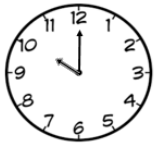
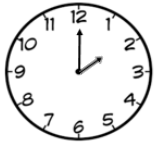

9



# Today's Number

Complete the activities below with this number.



41

forty-one

41

Count forward

41, \_\_\_\_\_, \_\_\_\_\_, \_\_\_\_\_, \_\_\_\_\_, \_\_\_\_\_, \_\_\_\_\_

Count backward

\_\_\_\_\_, \_\_\_\_\_, \_\_\_\_\_, \_\_\_\_\_, \_\_\_\_\_, \_\_\_\_\_, \_\_\_\_\_, 41

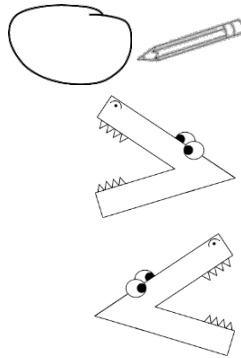

41

50

41	+1	
41	-1	

41	+10	
41	-10	

# Day 4

10



Exercise and Sleep  
Journal- Favorite Exercise

11



Tangrams

12



Telling Time



Start with today's new words!

<p>1</p> 	<p>3</p> <p>exercise</p> <p>4</p>
<p>2</p>	<p>4</p>

<p>1</p> 	<p>3</p> <p>sleep</p> <p>4</p>
<p>2</p>	<p>4</p>

# 10 ⇒ Exercise and Sleep

Exercise is good for every part of your body!

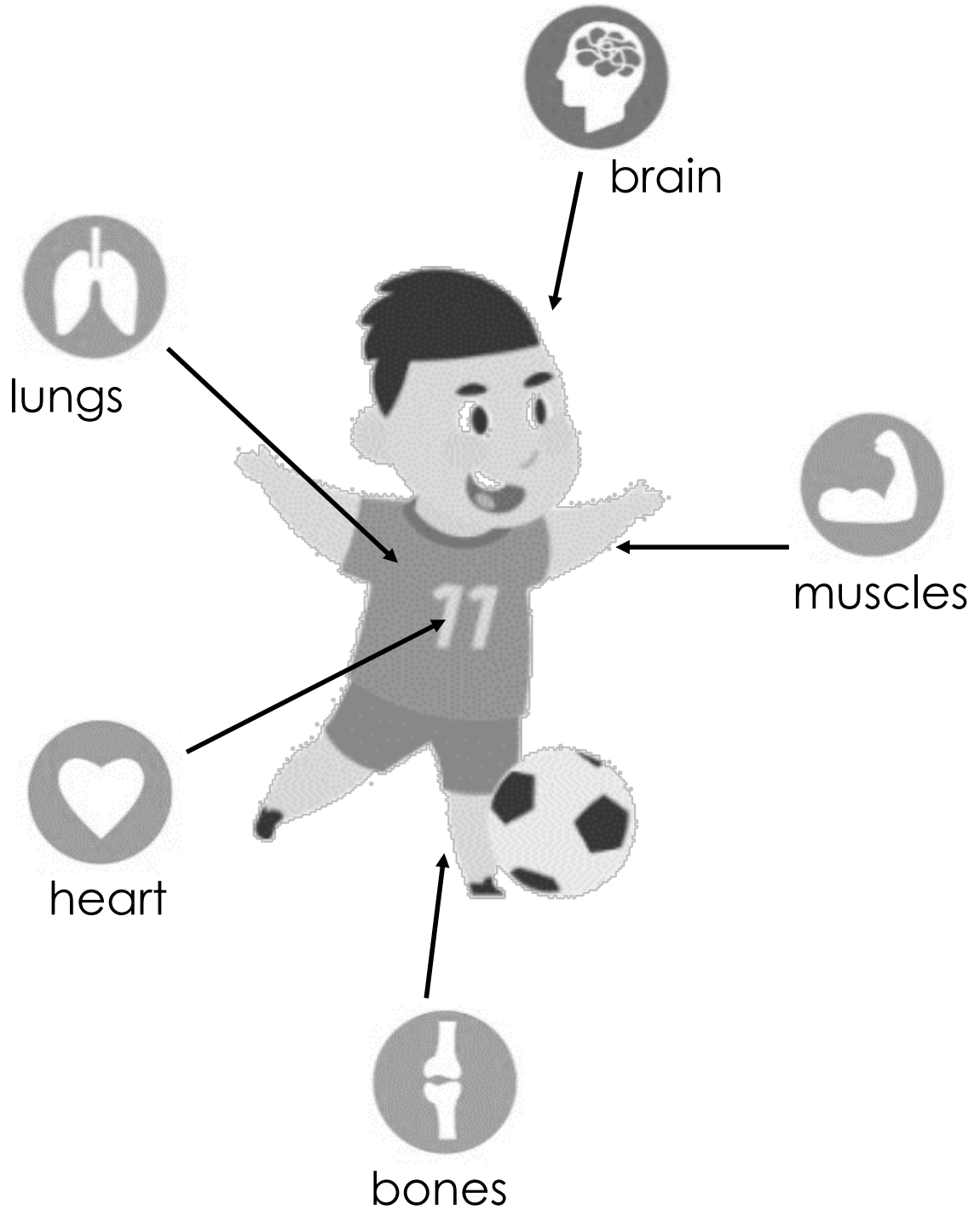



Sleep is so important for your body. It helps your brain grow and keeps you from getting sick.



## WHY IS SLEEP IMPORTANT?

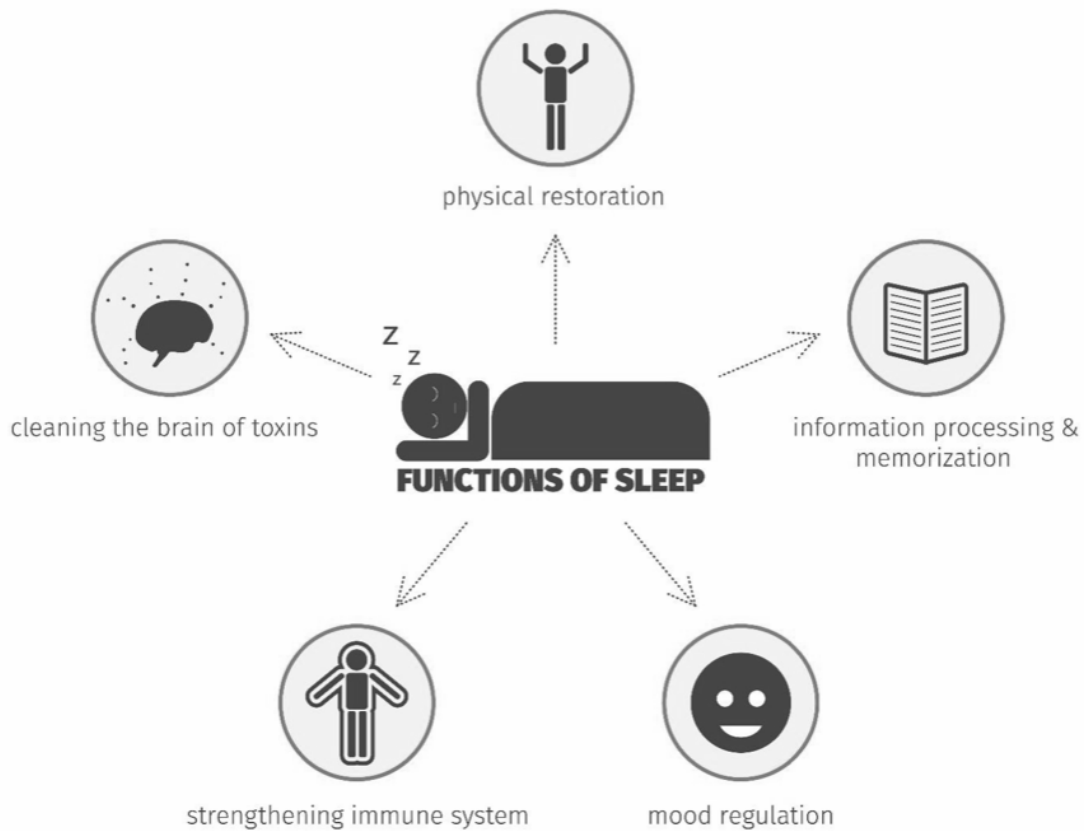



What is your favorite way to exercise?



Draw and color your idea.

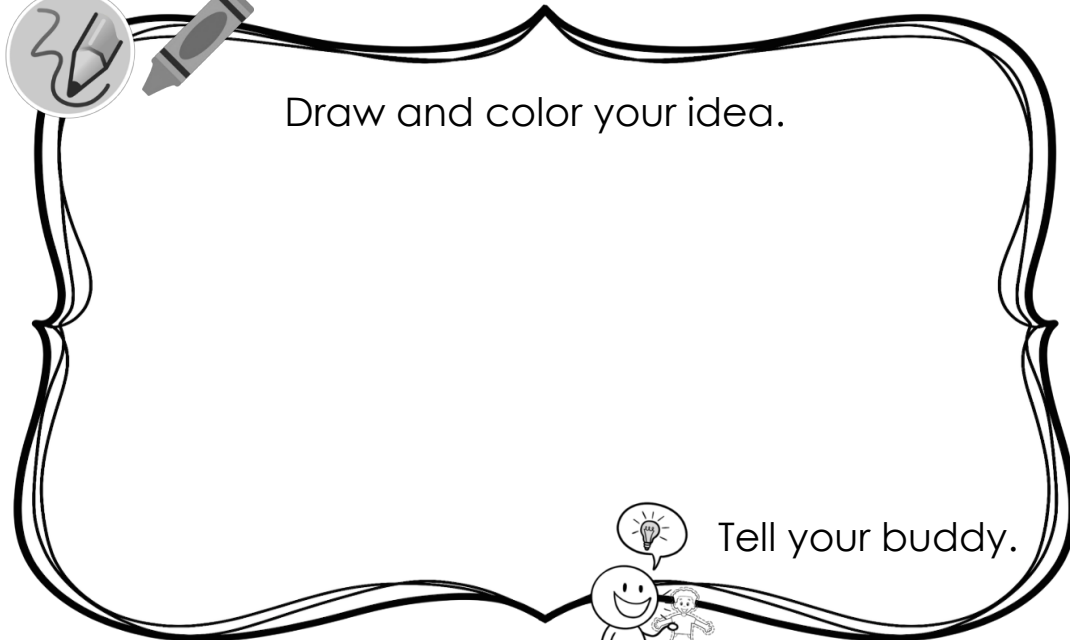

Tell your buddy.



Write your favorite exercise and tell why.

Handwriting practice lines consisting of solid top and bottom lines with a dashed middle line. There are four sets of these lines.



11



# Tangrams

Start by cutting these shapes apart.

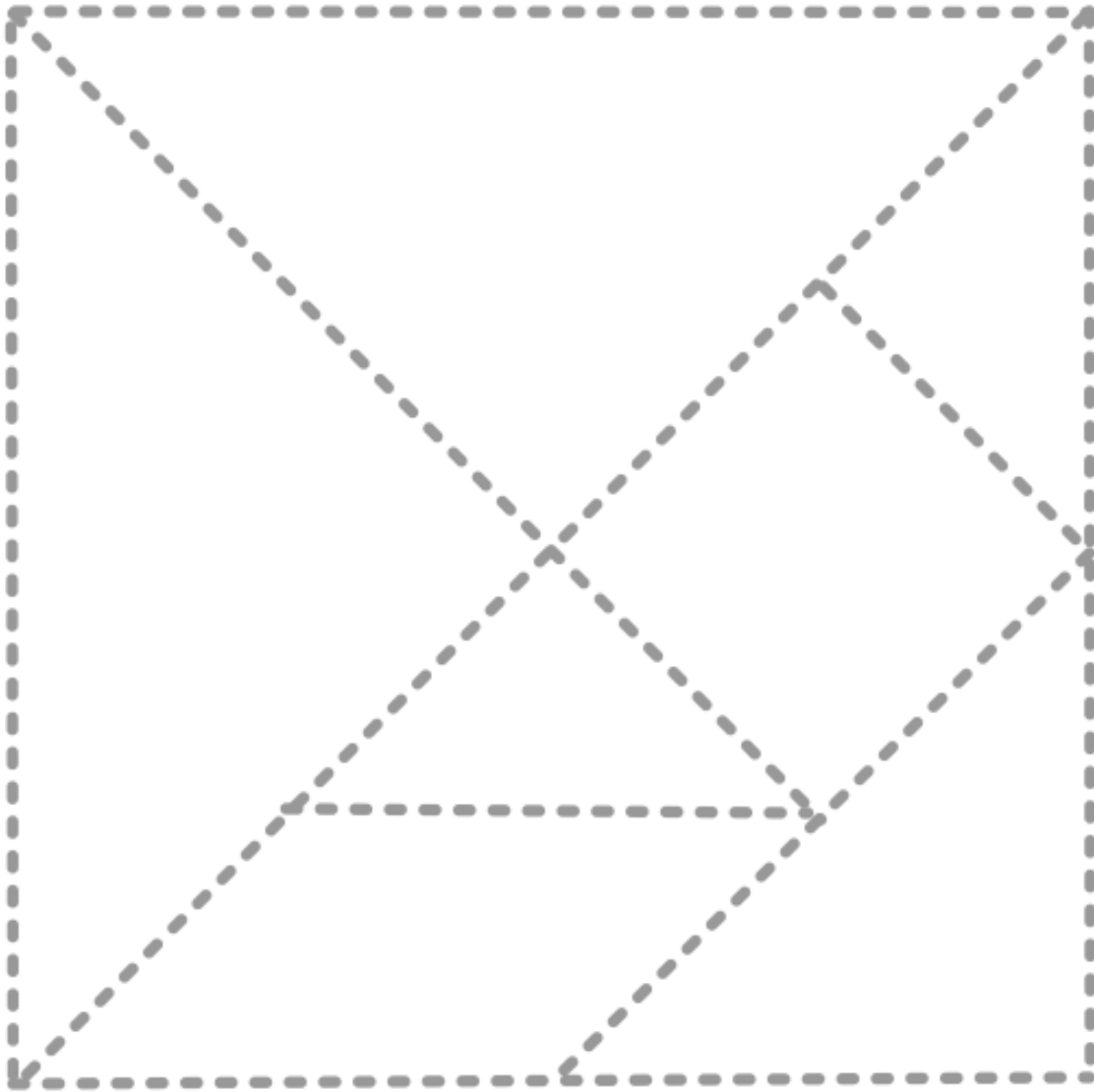

Use 2 pieces to make a square.

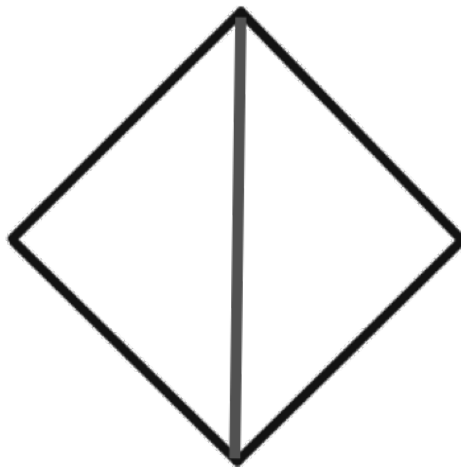

Use 3 pieces to make triangle.

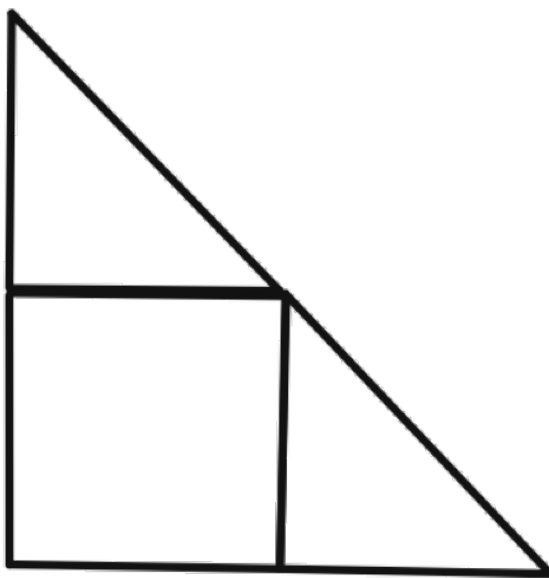

Use 3 pieces to make a triangle.

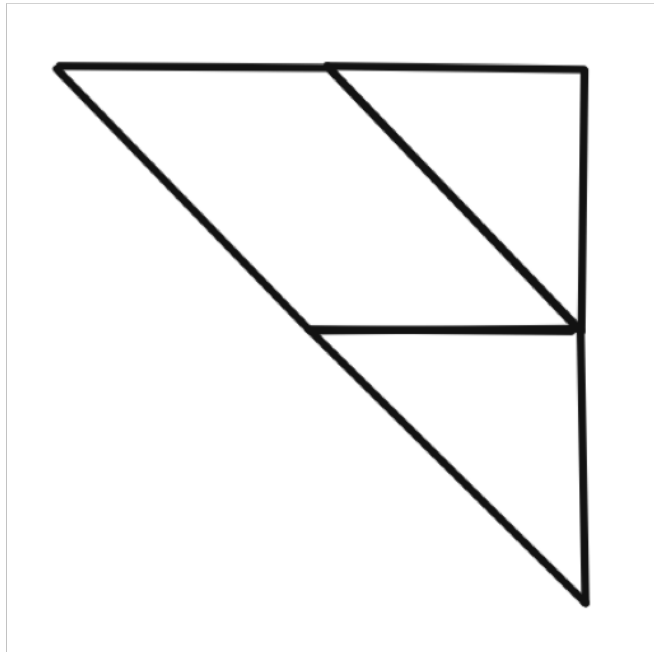

Use 4 pieces to make a square.

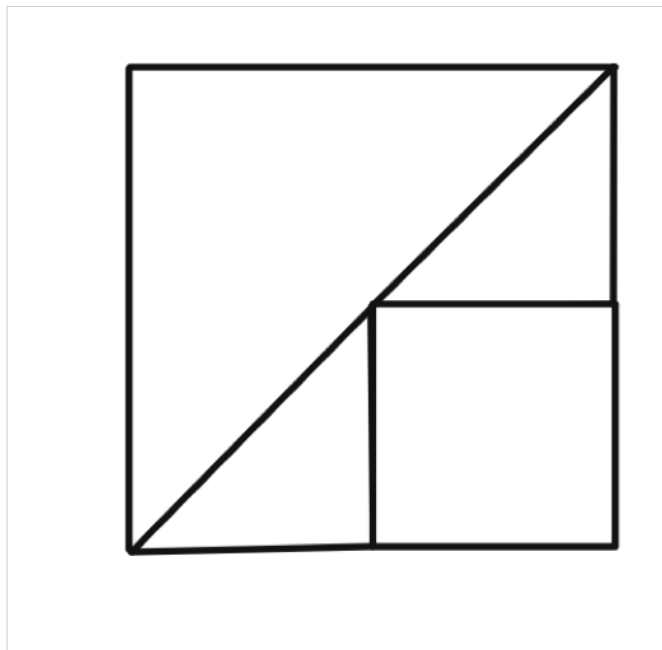

Use the pieces to make your own shape.



Can you use the pieces to match these figures?

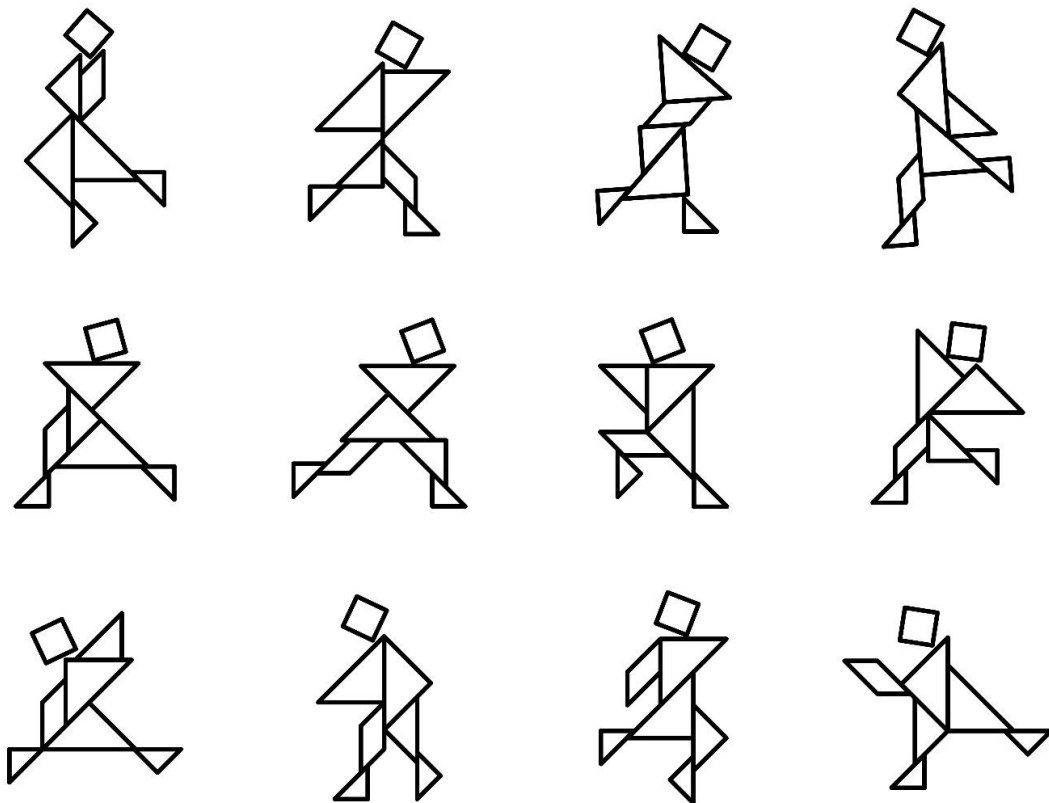

# 12 → Telling Time

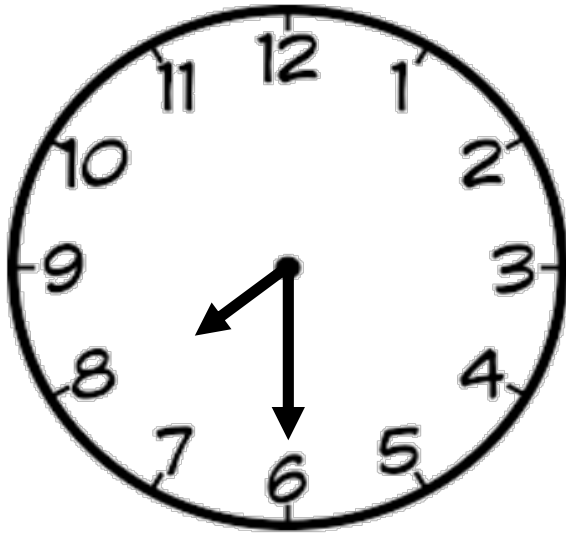

The small hand will be between two numbers. We say the earlier number for the hour. In this case, seven.



The large hand points to the minutes. When it points to the 6, that means 30 minutes, or half an hour.

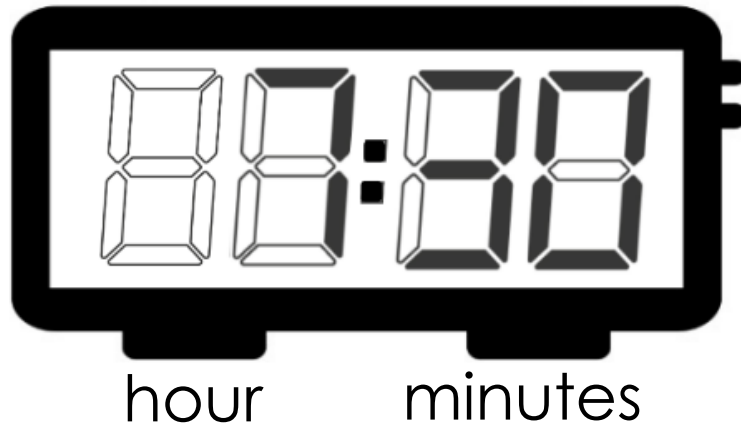

We say, “seven-thirty.”



Match the analog clock to the digital clock.

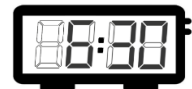
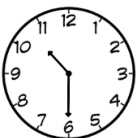
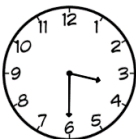
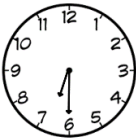
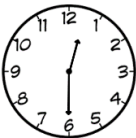
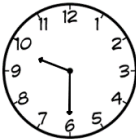
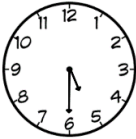
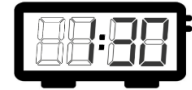
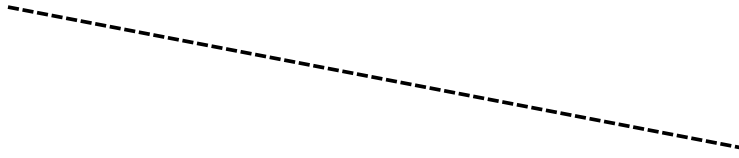
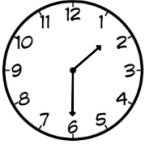







14



# What did you learn?



Think of your ideas.



Draw and color your ideas.



Tell your buddy.



Write your ideas.

15



## Tell Others!

Start by telling your buddy what you have learned. After that, share what you have learned three more times. Share with a person, a plant, a pet, or a toy.

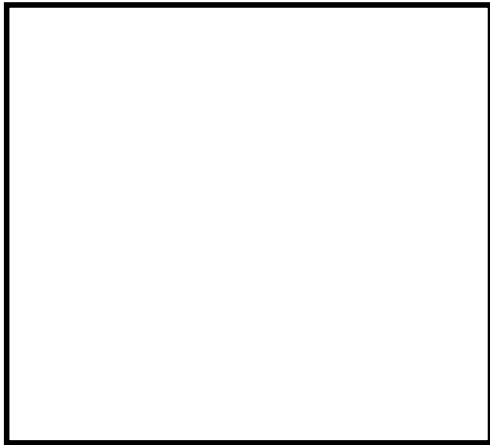
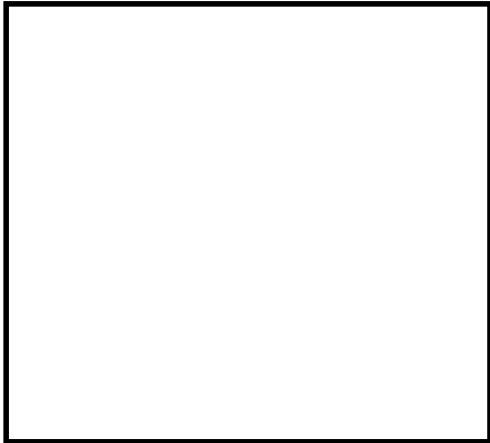





## My Packet Journal

Draw a picture about what you learned in this packet:

A large, empty rectangular box with a thin black border, intended for students to draw a picture about what they learned in the packet.

Write about what you learned in this packet:

Four horizontal lines provided for students to write about what they learned in the packet.

ICMEE is housed within:



